

## Installation and Setting-Up Instructions Spare Parts List



### Contents:

#### **1 INSTALLATION**

- 1.1 Mechanical installation
- 1.2 Electrical connections

#### **2 SETTING UP**

- 2.1 Applications/Liquid level measurement
- 2.2 Using the Hart® 275 user interface
- 2.3 Setting up through HART® 275 user interface
- 2.4 Using the Hart® 375 user interface
- 2.5 Setting up through HART® 375 user interface
- 2.6 Setting up with Satron-pAdvisor Service Software and Satron SI-Tool, USB-Hart modem
- 2.7 Setting up with local switches
- 2.8 Set-up calibration

#### **3 CALIBRATION**

- 3.1 Adjustability
- 3.2 Damping
- 3.3 Calibration examples

#### **4 CONSTRUCTION AND OPERATION**

#### **5 PARTS LIST**

### DOCUMENTS

Technical Specifications: BLVT830

Installation and Setting-Up Instructions: BLVT830AV

We reserve the right for technical modifications without prior notice.  
HART® is a registered trademark of HART Communication Foundation.  
Hastelloy® is the registered trademark of Haynes International.  
Viton® is the registered trademark of DuPont Down Elastomers.



**Satron Instruments Inc.**

P.O.Box 22, FIN-33901 Tampere, Finland  
Tel.int. +358 207 464 800, Telefax +358 207 464 801  
[www.satron.com](http://www.satron.com), [info@satron.com](mailto:info@satron.com)

## 1 INSTALLATION

### 1.1 Mechanical installation

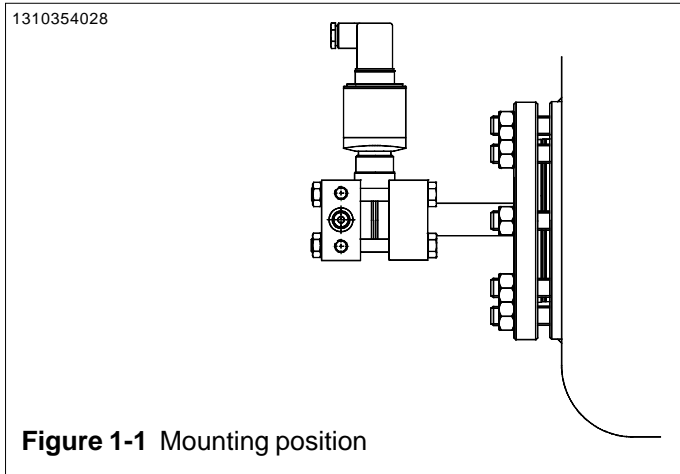


Figure 1-1 Mounting position

#### Recommended mounting position (Figure 1-1)

- Calibration direction and PLUG connector's coupling direction: horizontal
- Cable entry direction: from below
- Process connection direction: horizontal

#### General

Flange-mounted transmitter is installed directly on the side of a tank. As a result the measurement conditions may be quite demanding. As far as possible, however, the location of the transmitter should be such that the effects of temperature variations will be as small as possible. Mechanical stresses, such as vibration, should also be avoided as far as possible.

#### Impulse piping

Figure 1-2 shows an example of a flange-mounted transmitter's impulse piping for liquid level measurement in a pressurized tank.

For level measurement in open tank, omit parts 1-7.

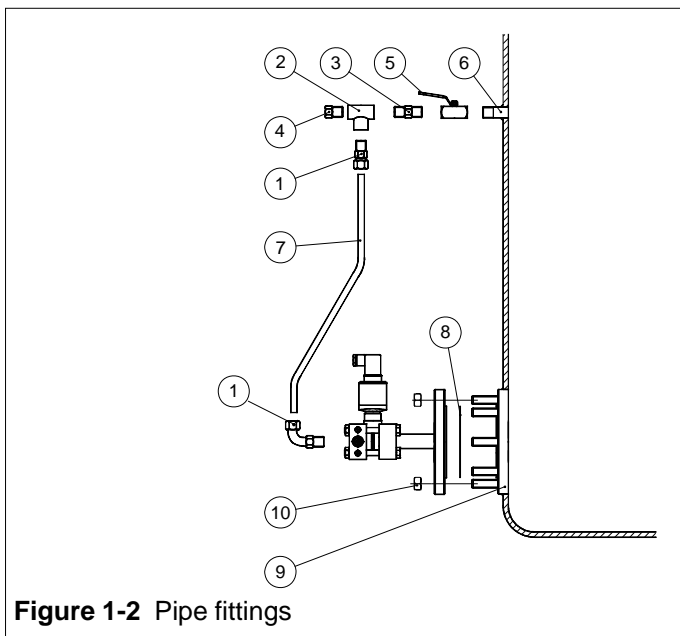


Figure 1-2 Pipe fittings

Table for Figure 1-2: Mounting accessories

1. Stud coupling Ø12 mm / G 1/2 male
2. T-coupling Ø12 mm
3. Stud coupling Ø12 mm
4. Plug
5. Ball valve
6. Coupling G1/2
7. Pipe 12 x 1 calibrated
8. Sealing DN80 <sup>1)</sup>
9. Flange coupling DN80
10. Nut

**NOTE!** The materials for pipe fittings should be chosen to withstand the ambient and process conditions.

<sup>1)</sup> The pickling of the pipework and tank should be taken into account when choosing the sealing materials. The materials should resist any absorption of the pickling material in the seal. E.g. Viton® is recommended.

#### Dimensions process connections Ax, Dx and JX

FLANGE SIZE	Flange dimensions			Holes			Code
	b	D	Ød <sub>4</sub>	Qty	d <sub>2</sub>	k	
ISODN80 PN40	24	200	138	8	18	160	DC
ISO DN100 PN40	24	235	162	8	22	190	DD
ANSI 3" 150 lbs	26	191	127	4	20	152.4	AE
ANSI 3" 300 lbs	31	210	127	8	23	168.3	AF
ANSI 4" 150 lbs	26	229	157	8	20	190.5	AG
ANSI 4" 300 lbs	34	254	157	8	23	200	AH
JIS 10K 80	18	185	126	8	19	150	JC
JIS 40K 80	32	210	140	8	23	170	JD
JIS 10K 100	18	210	151	8	19	175	JE
JIS 40K 100	36	250	165	8	25	205	JF

#### Dimensions of the process connections Ax, Dx and Jx with extension

	Extension code			
	0	2	4	6
Dim. E	0	51	102	152

#### Dimensions of the process connections SA (Sandvik-Clamp)

	Extension code		
	2	4	6
Dim. Es	54.5	105	156

Dimensions (in mm)

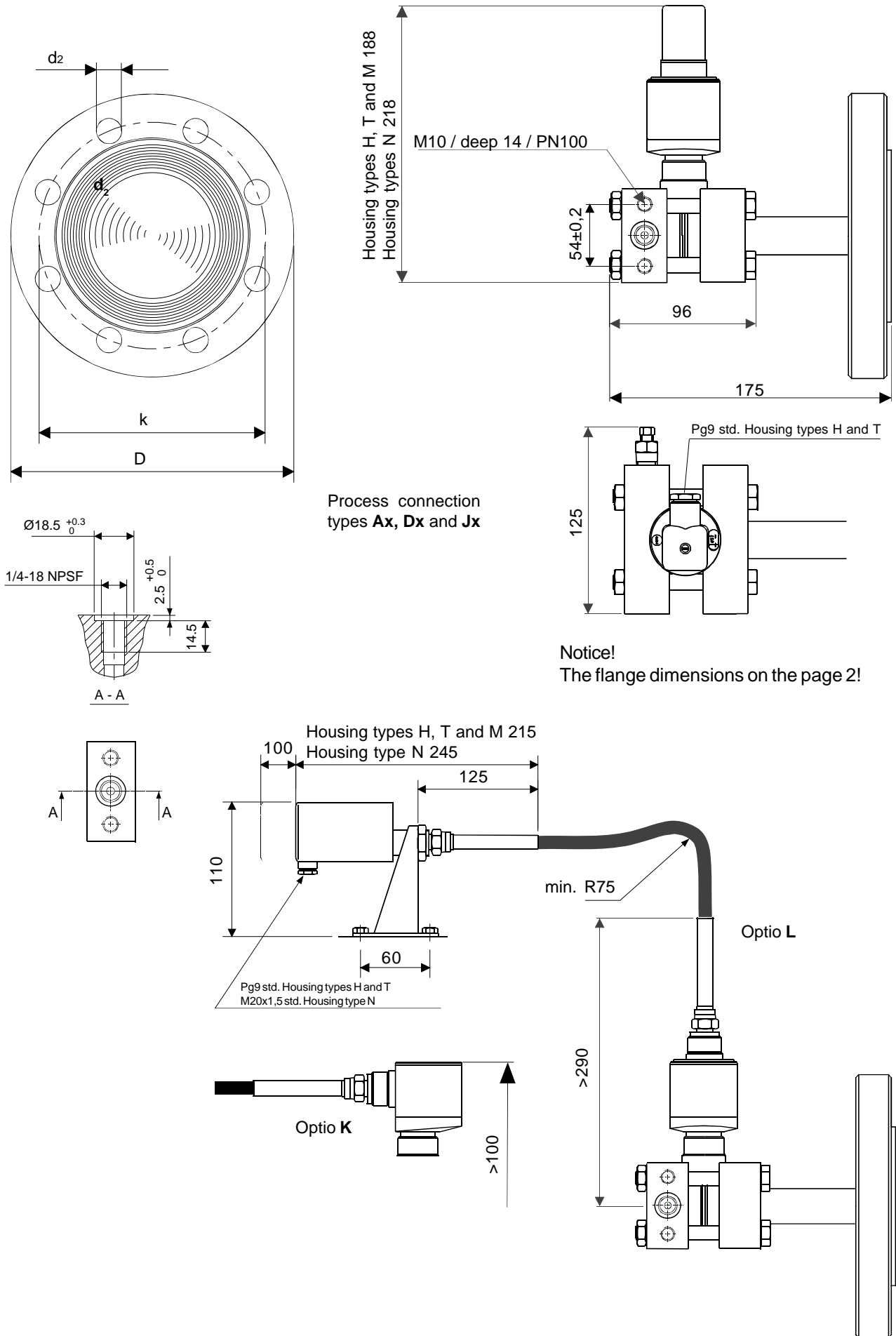
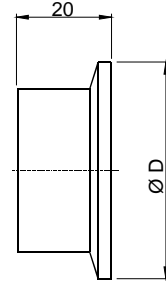
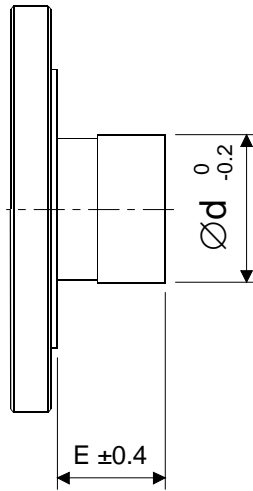
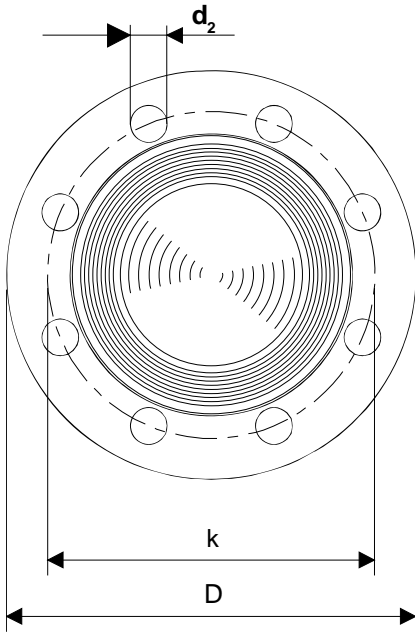


Figure 1-3a Dimensions

Dimensions (mm)

Notice!

The flange dimensions on the page 2!



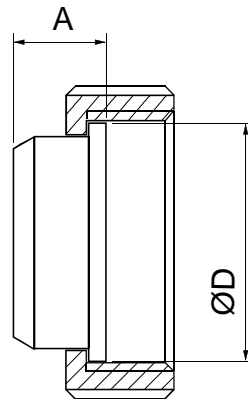
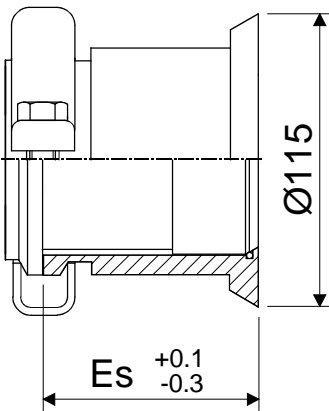
Process connection types **TA**, **TB** and **TC**

- Tri-clamp DN38 ... 63,5

DN	ØD
38	50,5
51	64
63,5	77,5

Process connection types Ax, Dx and Jx, with extension

	Extension code			
	0	2	4	6
Dim.E	0	51	102	152



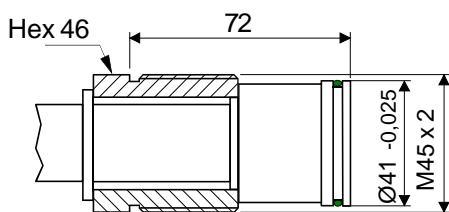
Process connection types **VA** and **VB**

- SMS38 and SMS51

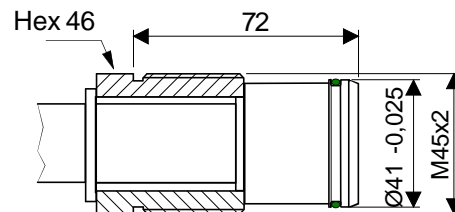
Process connection type **SA**

	Extension code		
	2	4	6
Dim. Es	54.5	105	156

Size	Dimensions		Thread
	ØD	A	
38	54	21	Rd 60 x 1/6
51	64	23	Rd 70 x 1/6



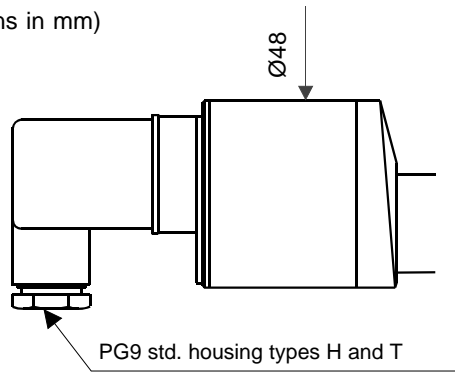
Process connection **BA**  
- M45x2



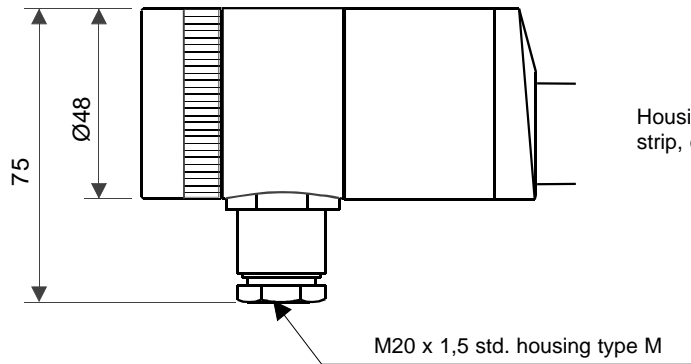
Process connection **BB**  
- M45x2 with tapered

Figure 1-3b Dimensions

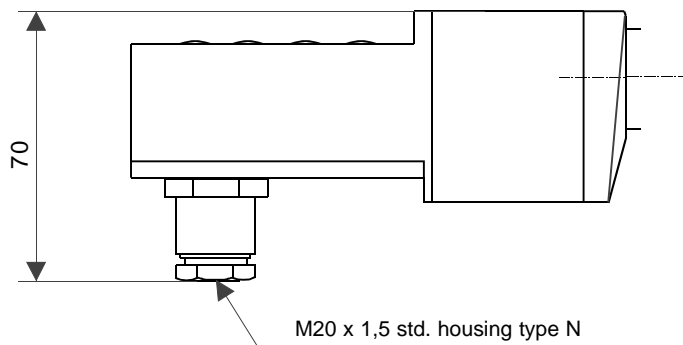
Dimensional drawings (dimensions in mm)



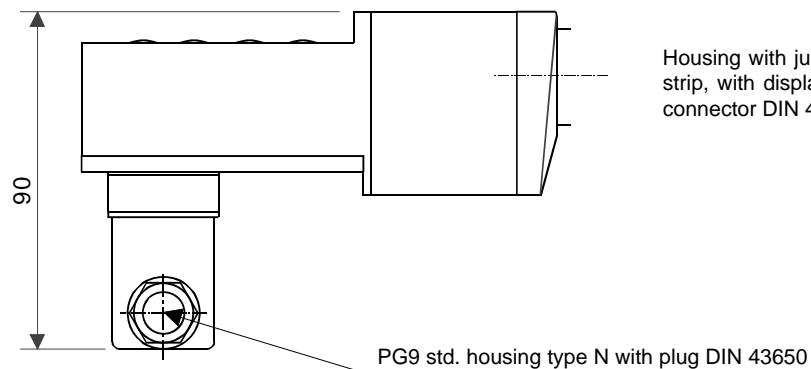
Housing with plug-connector, DIN 43650, codes H and T



Housing with junction box/terminal strip, code M



Housing with junction box/terminal strip, with display, code N



Housing with junction box/terminal strip, with display and plug-connector DIN 43650, code N- / P

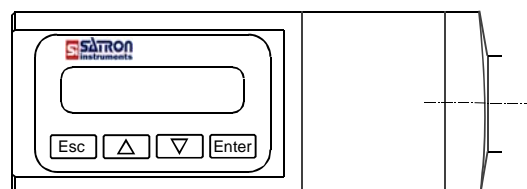
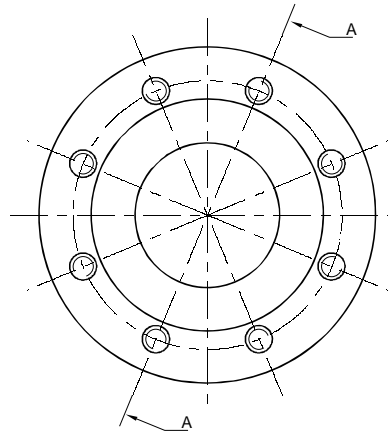
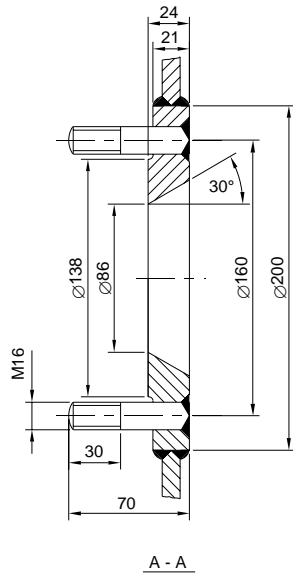


Figure 1-3c Dimensions



(Order no. M546606  
incl. hex nuts M16 and seal)

**Figure 1-4** Flange coupling

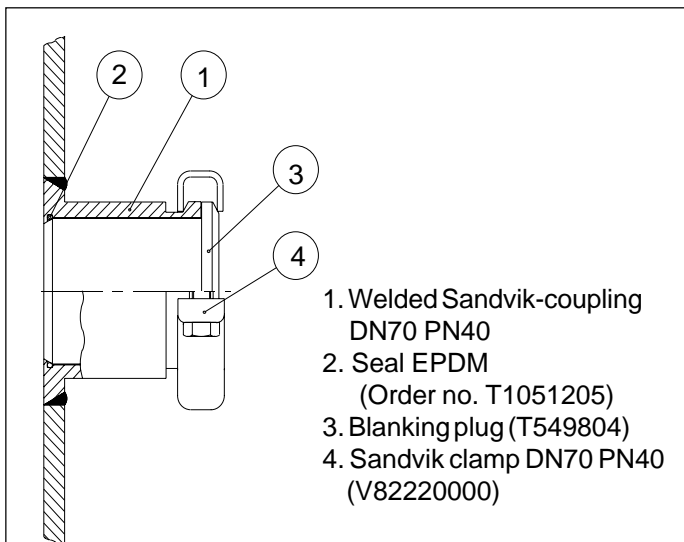
10044094

### Reference pressure

Reference pressure can be connected to both transmitter types (see Selection Table) through a flange adapter which facilitates the disconnection and connection from/to process.

Reference pressure can also be brought to the sensing element through a hydraulic pressure seal, whose capillary tube is connected directly to the process flange's 1/4-NPSF thread or welded, depending on the type of the pressure seal. The capillary filling and connections are factory made. The capillary connections must not be opened during installation because air would start dissolving in the seal fluid immediately, which would change the quantity of fill fluid in the unit. Air and quantity of fill fluid affect the measurement accuracy significantly. Any opened units must be sent to the manufacturer for refilling.

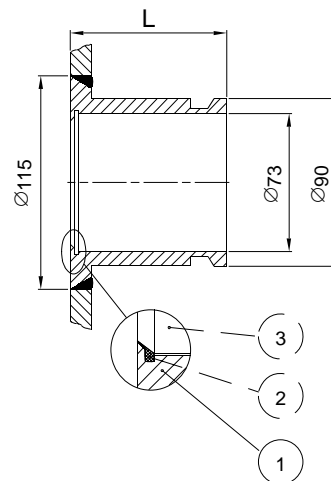
Ambient temperature variations will change the volume of the seal fluid. This will affect to the measurement accuracy. For this reason the hydraulic pressure seal's capillary should be protected against ambient temperature variations.



1. Welded Sandvik-coupling DN70 PN40
2. Seal EPDM (Order no. T1051205)  
Options: FPM (Order no. T1051204)  
PTFE (Order no. T1051203)
3. Blanking plug (T549804)
4. Sandvik clamp DN70 PN40 (V82220000)

**Figure 1-5** Sandvik blanking plug

10034029



- Coupling length L :
- Code 2 = 53 mm
  - Code 4 = 104 mm
  - Code 6 = 155 mm

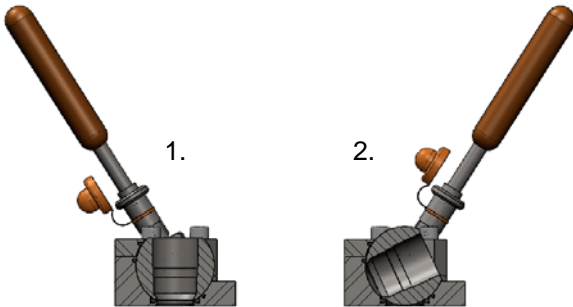
When welding the coupling, avoid ovaling or straining the bevelled joint (e.g. several rounds with small run; blanking plug can be used during welding to prevent ovaling of the coupling).

1. Welded Sandvik coupling DN70 PN40
2. Seal EPDM (Order no. T1051205)  
Options: FPM (Order no. T1051204)  
PTFE (Order no. T1051203)
3. VDtL-transmitter with Sandvik -process connection

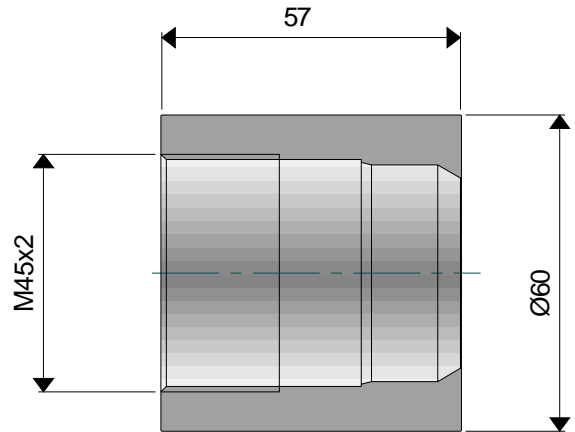
**Figure 1-6** Welded Sandvik coupling

10034030

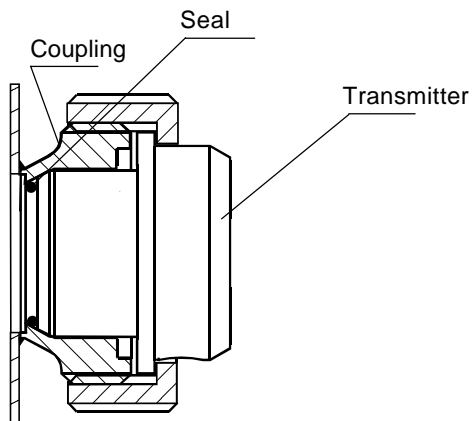
For process connections **BA3** and **BB**  
 1. Transmitter in measuring  
 2. Transmitter can be checked, changed, calibrated or the transmitter diaphragm can be flushed



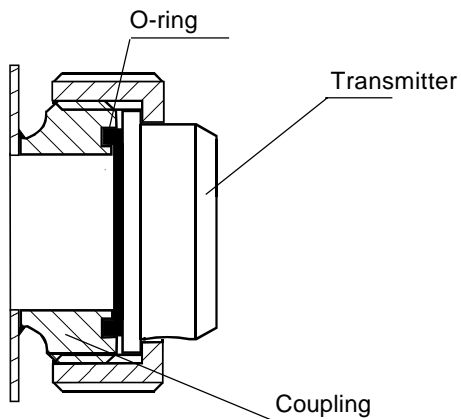
**Figure 1-7** Pasve Ba working position



**Figure 1-10** Coupling BB M45x2, for process connection **BB**, order code **M1050474** (Welding assistant, code M1050473)

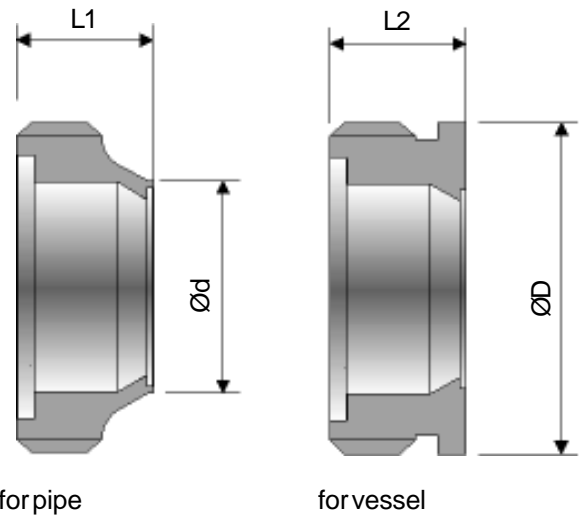


**Figure 1-8** Mounting type **SMS-SI**



**Figure 1-9** Mounting type **SMS**

**SMS-SI** couplings :



Size	Dimensions				Thread
	L1	Ød	L2	ØD	
38	27	38,5	24	60	Rd 60 x 1/6
51	30	51	25	70	Rd 70 x 1/6

**Figure 1-11** Mounting dimension type **SMS-SI**

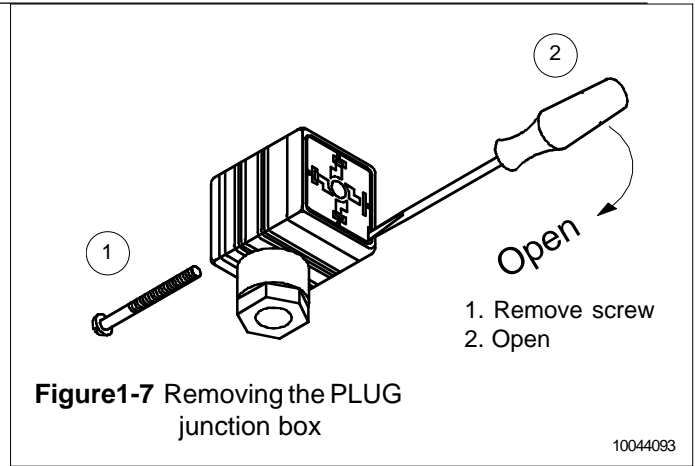
## 1.2 Electrical connections

Supply voltage and load of the transmitter according to the figure 1-8.

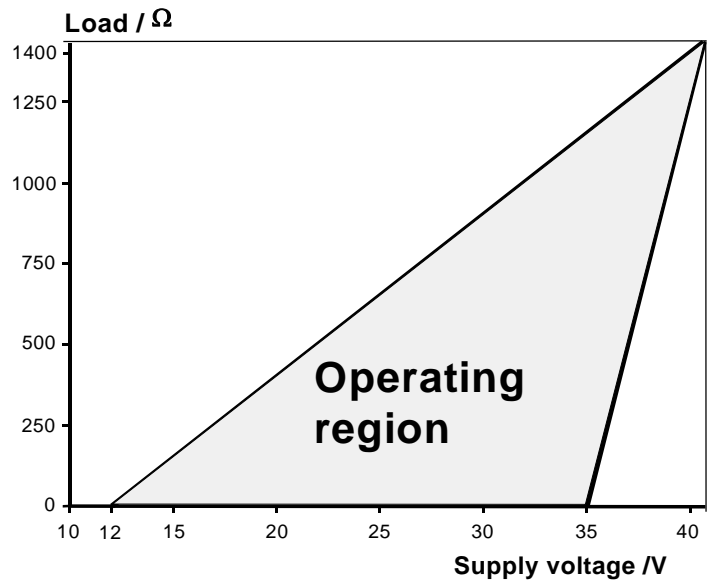
We recommend shielded twisted-pair cable as signal cable.

The signal cable should not be installed near high-voltage cables, large motors or frequency converters.

The shield of the cable is grounded at the power supply end or according to the recommendations of the manufacturer of the used control system.



1300354153



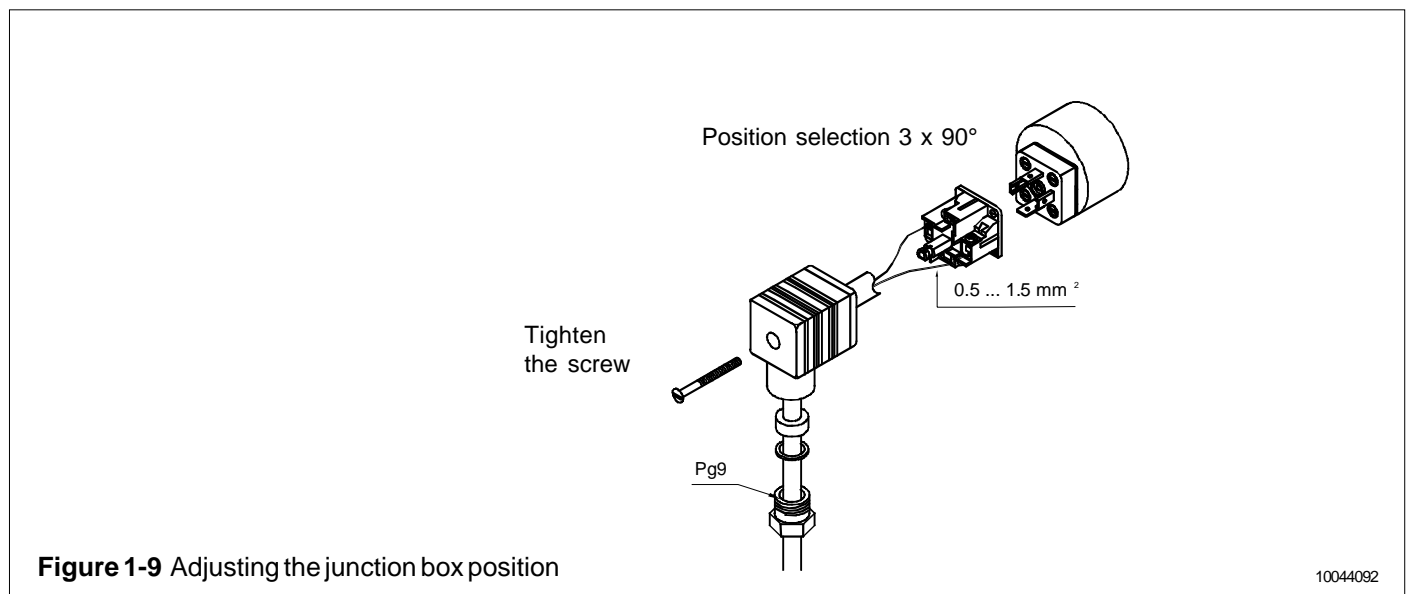
Min. load using HART® - communication 250 Ω

$$R_{\max} = \frac{\text{Supply voltage} - 12 \text{ V}}{I_{\max}}$$

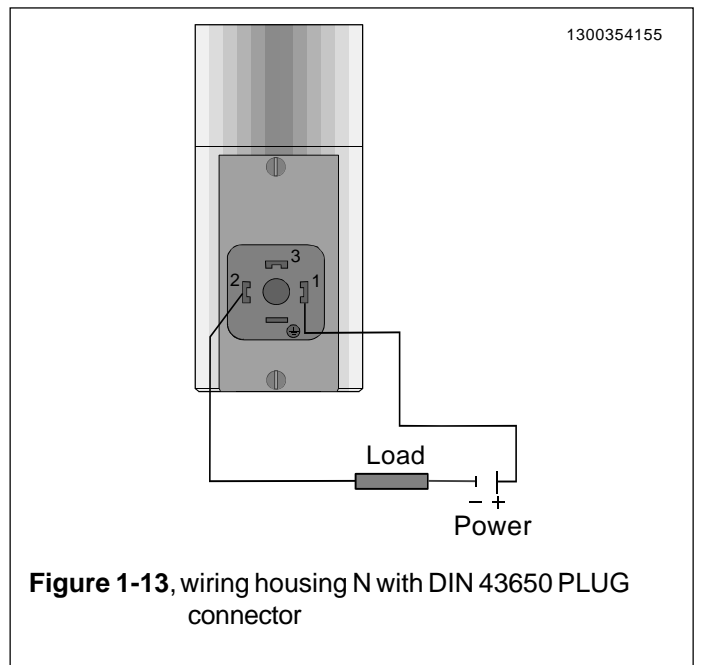
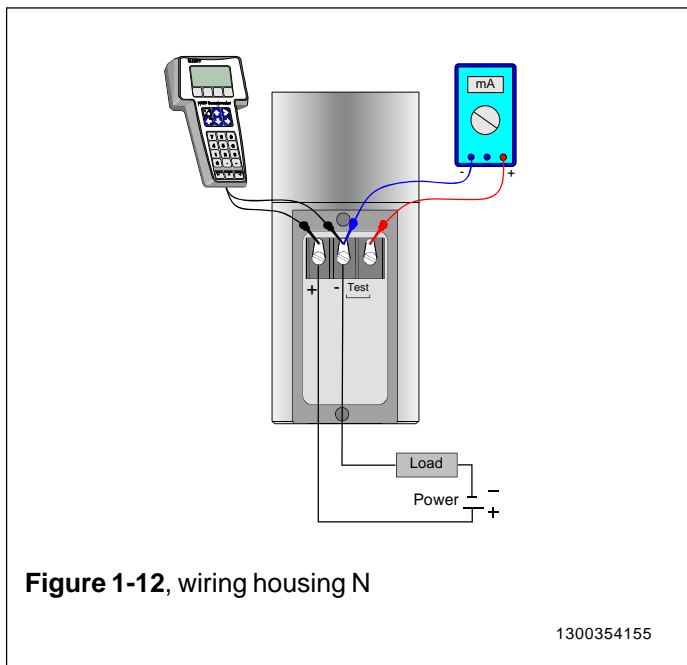
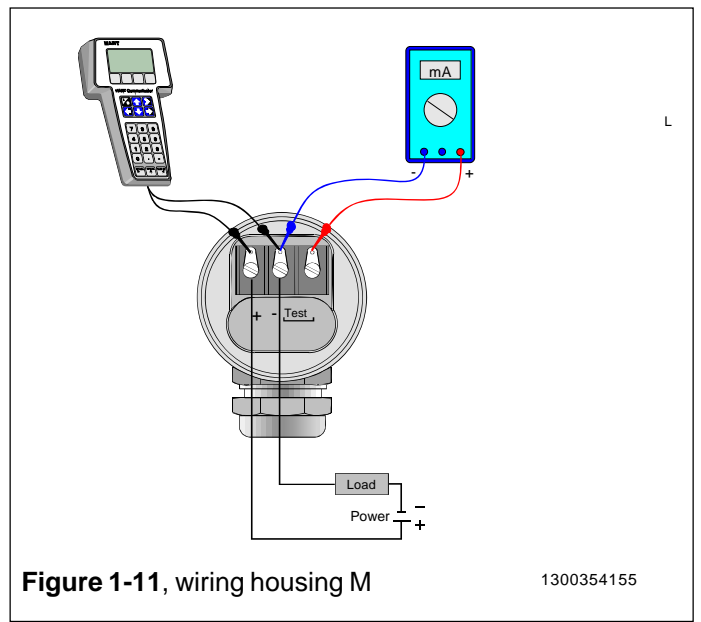
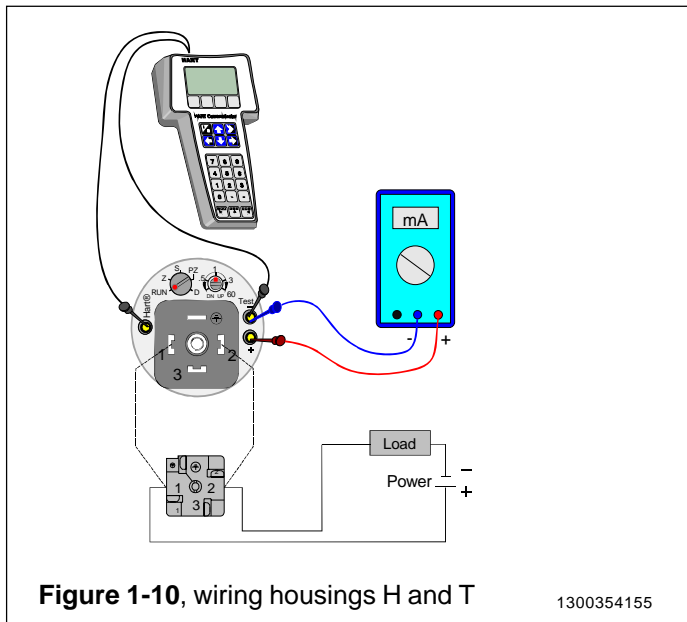
$I_{\max} = 20.5 \text{ mA}$  using HART®-communication

$I_{\max} = 23 \text{ mA}$  (when the alarm current 22,5 mA is on)

**Figure 1-8** Supply voltage and load capacity







## 2 SETTING UP

Setting up is dependent on type of user interface and loaded description **VALMET** or **SATRON**.

Also must be noted that when the older **VALMET** description is in use then the transmitter must be configured so that it can operate with the old **VALMET** description.

The change from description to another is made by writing to **MESSAGE**-field either. **VALMET** or **SATRON** (Note, capital letters and dot in front).

After writing the message the new description will be activated by switching transmitter's power **OFF** and **ON** again.

## 2.1 Applications/Liquid level measurement

### Open tank

Liquid level measurement with pressure transmitter is based on the measurement of the liquid's static pressure. Static pressure does not depend on the shape or volume of the vessel. It can be calculated by multiplying the liquid's density by the liquid level and acceleration of gravity:

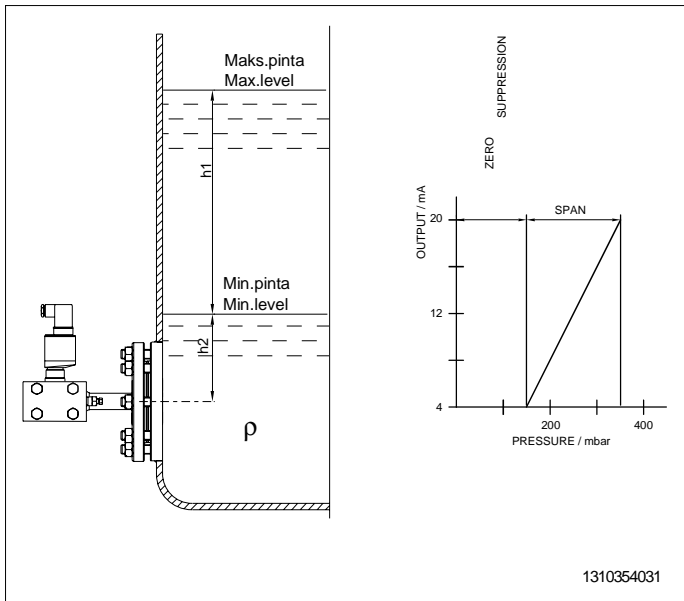
$$p = \rho h g$$

where  $p$  = static pressure  
 $\rho$  = density  
 $h$  = height of liquid level  
 $g$  = acceleration of gravity

The pressure acting on the flange diaphragm is thus directly proportional to the height of the liquid level, and the transmitter can be calibrated to measure liquid level. Atmospheric pressure is applied to the reference pressure connection.

The lower limit of the liquid level is normally above the transmitter. This is taken into account through zero suppression.

### Example:



$h_1$  = difference between maximum and minimum height of measured level (2.5 m)  
 $h_2$  = level's minimum height from transmitter (1.5 m)  
 $\rho$  = density of measured liquid (950 kg/m<sup>3</sup>)  
 $g$  = acceleration of gravity (9.81 m/s<sup>2</sup>)

Span ( $p_1$ ) and zero suppression ( $p_2$ ) will then be as follows:

$$p_1 = h_1 \rho g = (2.5 \text{ m}) (950 \text{ kg/m}^3) (9.81 \text{ m/s}^2) = \underline{23.3 \text{ kPa}}$$

$$p_2 = h_2 \rho g = (1.5 \text{ m}) (950 \text{ kg/m}^3) (9.81 \text{ m/s}^2) = \underline{14.0 \text{ kPa}}$$

$$\text{Measuring range} = p_2 \dots (p_2 + p_1) = \underline{14 \text{ kPa} \dots 37.3 \text{ kPa}}$$

$$(140 \text{ mbar} \dots 373 \text{ mbar})$$

### Closed tank

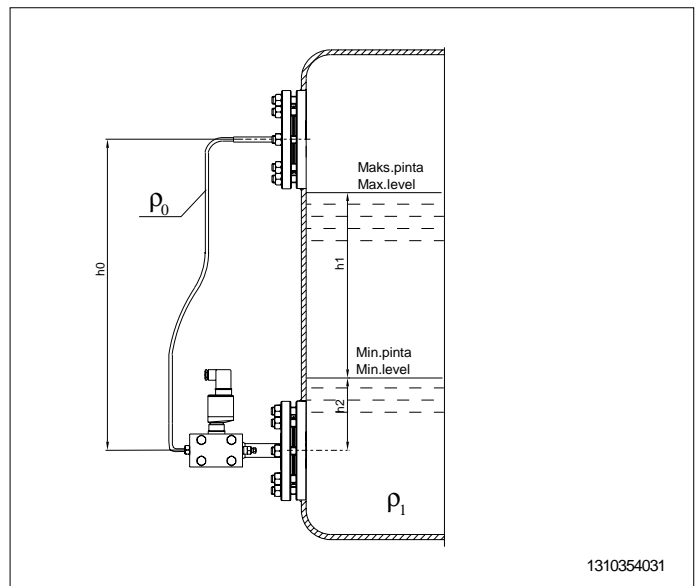
Besides the pressure proportional to liquid level, any excess pressure or negative pressure in the tank will also act on the flange diaphragm.

Pressure existing above the liquid surface is taken into account by applying it to the low-pressure side (negative side) of the differential pressure transmitter. The differential pressure acting across the sensing element is thus directly proportional to the height of the liquid level, and any pressure variations that may occur above the liquid surface are eliminated from the measurement.

Condensed liquid or purging water which is present in the reference pressure line as a so-called negative leg causes a static pressure. It will also be present when using a hydraulic pressure seal. The static pressure is taken into account through zero elevation.

The required zero elevation can be calculated by subtracting the pressure caused on the transmitter by a liquid column corresponding to minimum level from the static pressure acting on the transmitter's low-pressure side.

### Example:



$h_1$  = difference between maximum and minimum height of measured level (3.5 m)

$h_2$  = level's minimum height from transmitter (1.0 m)

$\rho_1$  = density of measured liquid (950 kg/m<sup>3</sup>)

$h_0$  = height of negative leg (5.0 m)

$\rho_0$  = density of liquid in negative leg (960 kg/m<sup>3</sup>)

Span ( $p_1$ ) will then be as follows:

$$p_1 = h_1 \rho_1 g = (3.5 \text{ m}) (950 \text{ kg/m}^3) (9.81 \text{ m/s}^2) = \underline{32.6 \text{ kPa}}$$

Pressures ( $p_2$  and  $p_0$ ) corresponding to minimum level and negative leg will be as follows:

$$p_2 = h_2 \rho_1 g = (1.0 \text{ m}) (950 \text{ kg/m}^3) (9.81 \text{ m/s}^2) = \underline{9.3 \text{ kPa}}$$

$$p_0 = h_0 \rho_0 g = (5.0 \text{ m}) (960 \text{ kg/m}^3) (9.81 \text{ m/s}^2) = \underline{47.1 \text{ kPa}}$$

Pressure corresponding to zero elevation will be:

$$p = p_2 - p_0 = \underline{-37.8 \text{ kPa}}$$

$$\text{Measuring range} = p \dots (p + p_1) = \underline{-37.8 \text{ kPa} \dots -5.2 \text{ kPa}}$$

$$(-378 \text{ mbar} \dots -52 \text{ mbar})$$

## 2.2 Using the 275 user interface

### Operation keys

The six operation keys are located above the alphanumeric keyboard:

The ON/OFF key (**I/O**) switches the user interface on and off. When you switch the user interface on, it starts looking for a HART® transmitter connected to it. If the transmitter is not found, the message “**No Device Found. Press OK**” will be displayed.

The **ONLINE** menu is displayed when the user interface finds the transmitter.

(**^**) This key allows you to move upwards in menus and scroll lists forwards.

(**v**) This key allows you to move downwards in menus and scroll lists backwards.

(**<**) This two-function key allows you to move the cursor to the left and to go back to a previous menu.

(**>**) This two-function key allows you to move the cursor to the right and to select a menu option.

(**>>>**) The quick-selection key will start the user interface and display the quick-selection menu. You can define the desired menu as quick-selection menu.

### Function keys

With function keys F1, F2, F3 and F4 you can perform the program functions displayed above each function key. When you move in the software menus, the functions of these keys will change in accordance with the currently selected menu.

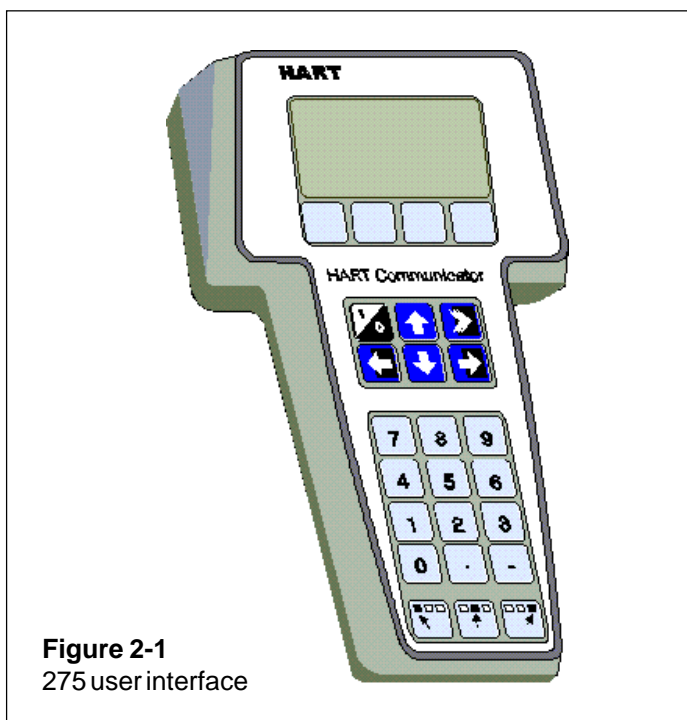


Figure 2-1  
275 user interface

## 2.3 Setting up through HART® 275 user interface

After installing and connecting the transmitter, connect the user interface to the transmitter. The following menu is displayed:

- 1 Measurement
- 2 Configuration
- 3 Information
- 4 Diagnostics

To change the measuring range, unit damping time constant to output mode (linear/square-root), select **Configuration**.

The following menu is then displayed:

- 1 Range values
- 2 Detailed config

To change the measuring range, select **Range values**.

The selection displays the following menu:

- 1 LRV (lower range value)
- 2 URV (upper range value)
- 3 LSL (lower sensor limit)
- 4 USL (upper sensor limit)
- 5 Min span (minimum span)
- 6 Apply values

To change the measurement unit, damping time constant or output mode, select **Detailed config** from the **Configuration** menu.

The selection displays the following menu:

- 1 Damping
- 2 Pres. unit
- 3 Tempr. unit
- 4 Alarm current
- 5 Write protect
- 6 Lin. func
- 7 Diff EI status
- 8 Burst mode
- 9 Burst option
- Poll addr
- Tag
- User function
- User funct. setup

After these activities or if the transmitter is supplied with the ready configuration you must correct a zero error of the transmitter in a final installation position.

Press **Diagnostics** and **PV Zero calibr.**

The selection displays the following menu: **Give correct value for Zero pressure in ...**

The current zero point will be shown in display and the final zero error correction can be done.

## 2.4 Using the 375 user interface



Figure 2-2  
375 user interface

The following menu is then displayed:

- 1 **Measurement**
- 2 **Configuration**
- 3 **Information**
- 4 **Diagnostics**
- 5 **Review**

To change the measurement unit, damping time constant or output mod, select **Configuration**.

The following menu is then displayed:

- 1 **Range values**
- 2 **Output**
- 3 **Transfer function**
- 4 **General setup**

To change the measurement unit, select **Range values**.

The following menu is then displayed:

- 1 **LRV**
- 2 **URV**
- 3 **LSL**
- 4 **USL**
- 5 **Min span**
- 6 **Apply values**

To change the damping time constant, select **Output** from the **Configuration** menu.

The following menu is then displayed:

- 1 **Damping**
- 2 **Alarm current**

To change the output mode, select **Transfer function** from the **Configuration** menu.

The following menu is then displayed:

- 1 **Lin. func**
- 2 **User function data**

After these activities or if the transmitter is supplied with the ready configuration you must correct a zero error of the transmitter in a final installation position.

The First press **Diagnostics** and then **Sensor trim** and then **Zero trim**

The following text is then displayed : *WARN-Loop be removed from automatic control*

The final zero error correction can be done to select **ABORT** or **OK** on the display .

## 2.5 Setting up through HART® 375 user interface and SATRON description

After installing and connecting the transmitter, connect the user interface to the transmitter. The following menu is displayed: **Main menu**. To select the **HART Application**.

## 2.6 Setting-up with Satron-pAdvisor Service Software

When you will have available all the operations of the Smart transmitter, we recommend the use of Satron-pAdvisor Service Software and Satron SI-Tool<sub>ε</sub> USB-Hart-modem in setting-up.

**Test connections for configuration and pressure/ output current values checking and calibration and for SENSOR TRIM function**

### Recommended equipment for calibration

Satron-pAdvisor service software for SATRON Smart transmitter (can be loaded free of charge from [www.satron.com](http://www.satron.com))

PC: operating system Win-98, Windows 2000 or Windows XP)

DMM: Digital multimeter, basic DCV accuracy better than 0,01 % of reading (for example Fluke 8840A, Keithley 2000)

Cal. pressure generation and measurement device (accuracy better than 0,03 % of reading)

USB-Hart modem, Satron SI Tool<sub>ε</sub>, order code: **M1330001**

Digital multimeter for output current measuring

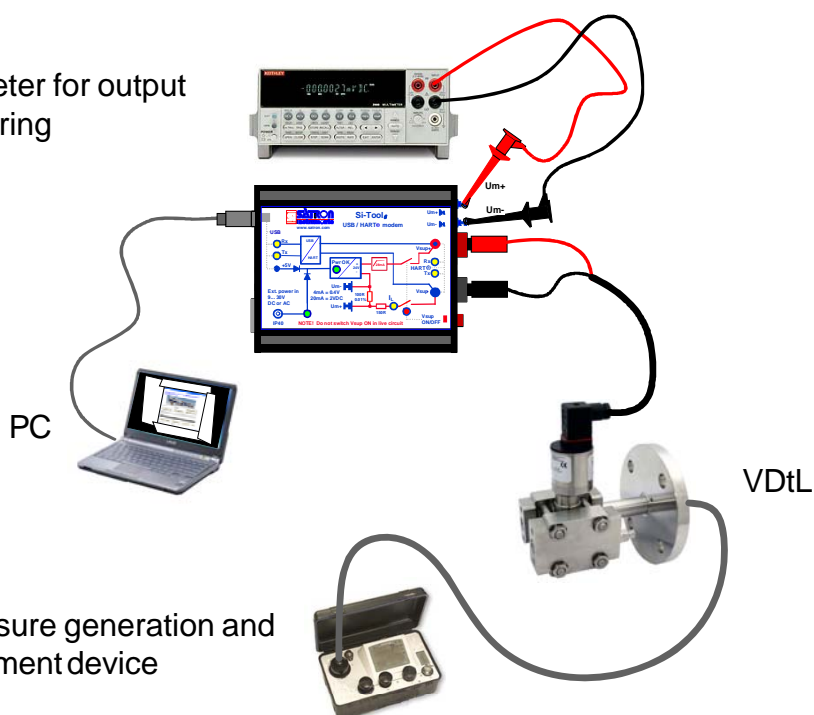


Figure 2-3 Calibration connections window

## 2.7 Setting-up with local switches

The additional instruction of display menus is enclosed to this manual.



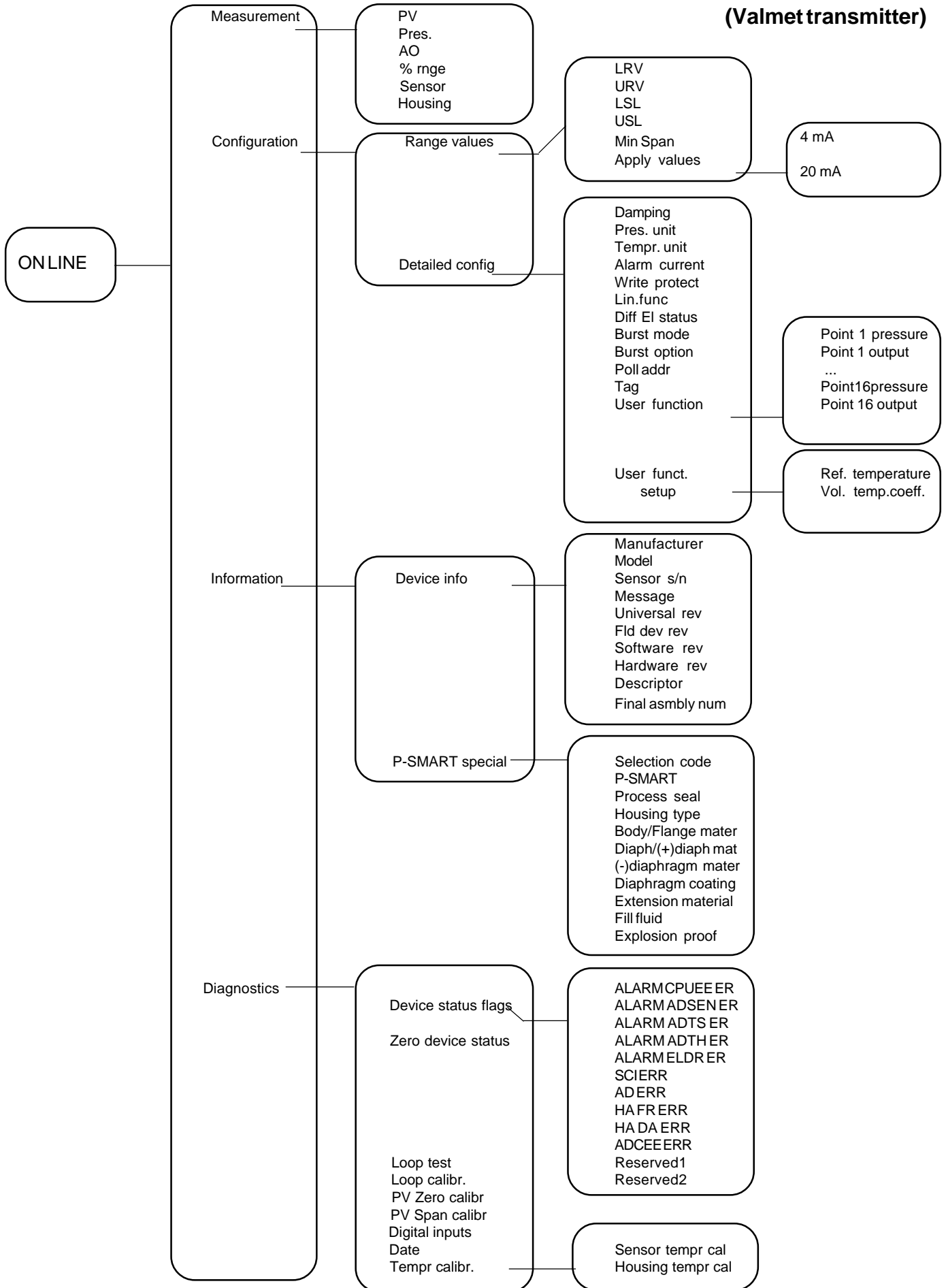
Keyboard :

- Esc = Press **Esc** move back towards the top of the main menu.
- ▲ = Use the **UP** arrow key to move up on the current menu level or to increase the selected parameter value.
- ▼ = Use the **DOWN** arrow key to move down on the current menu level or to decrease the selected parameter value.
- Enter = Press **ENTER** to move to a lower level in a menu or to accept a command or parameter value.

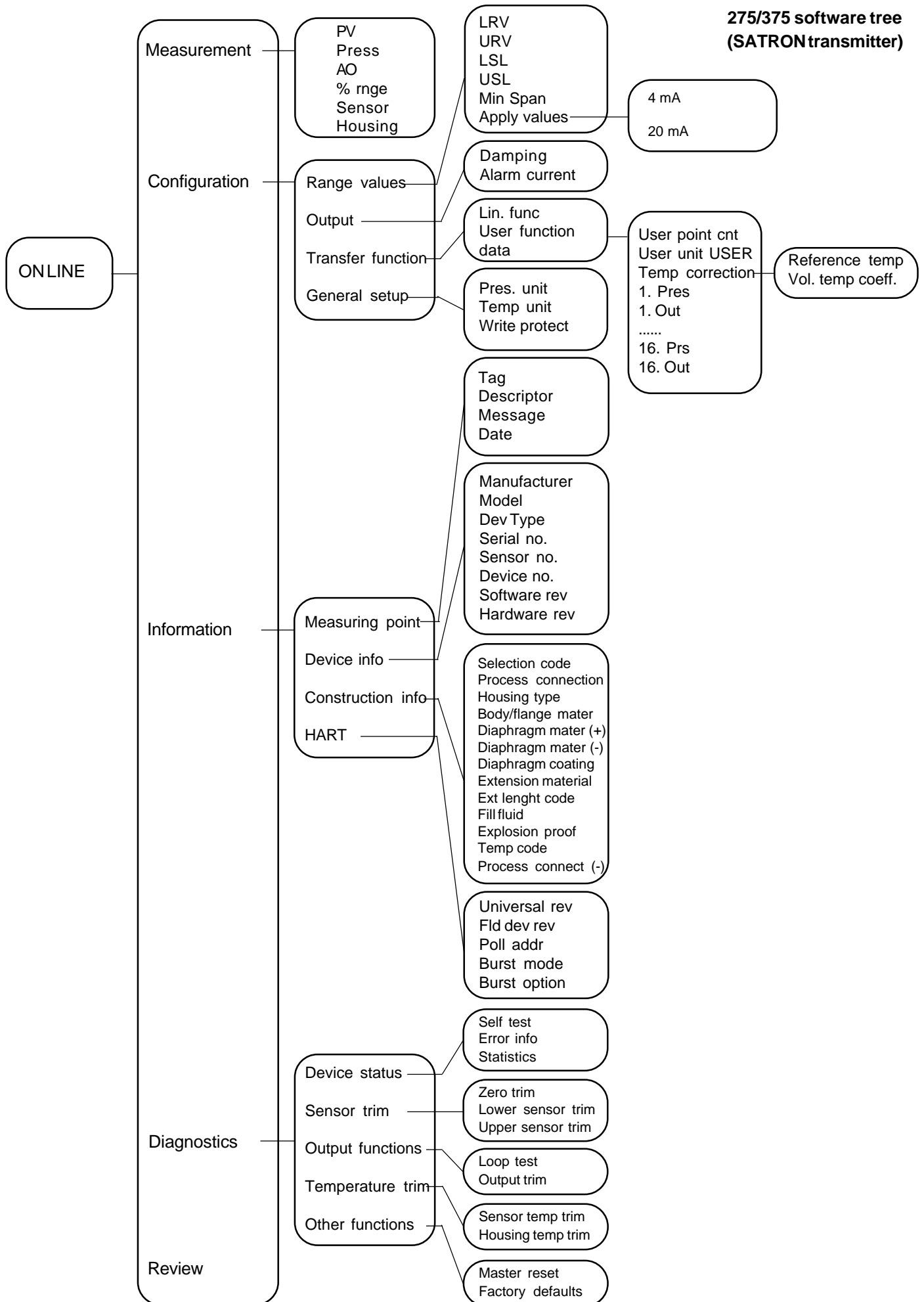
Figure 2-4 VDtL differential pressure transmitter with display

1300354154

## 275 software tree (Valmet transmitter)



275/375 software tree  
(SATRON transmitter)



## 2.8 Set-up calibration, housing code T (with manual adjuster)

The transmitter is factory-calibrated, with 1 sec. electrical damping, for the range specified in the order. If range is not specified, the transmitter will be calibrated for the maximum range.

Zero and Span adjusters are at the end of the housing, under protective rubber shield. TEST jacks are also under protective rubber shield. Figure 2-4: housing T with PLUG connector

### Checkout procedure

- See that the ripple on the supply voltage does not exceed  $2.5 V_{pp}$  on 0-1000 Hz frequency range.
- Check the nameplate for the factory-calibrated range and zero suppression/elevation.
- If necessary, readjust the zero. Guide for zeroing: see point 3.3. calibration example

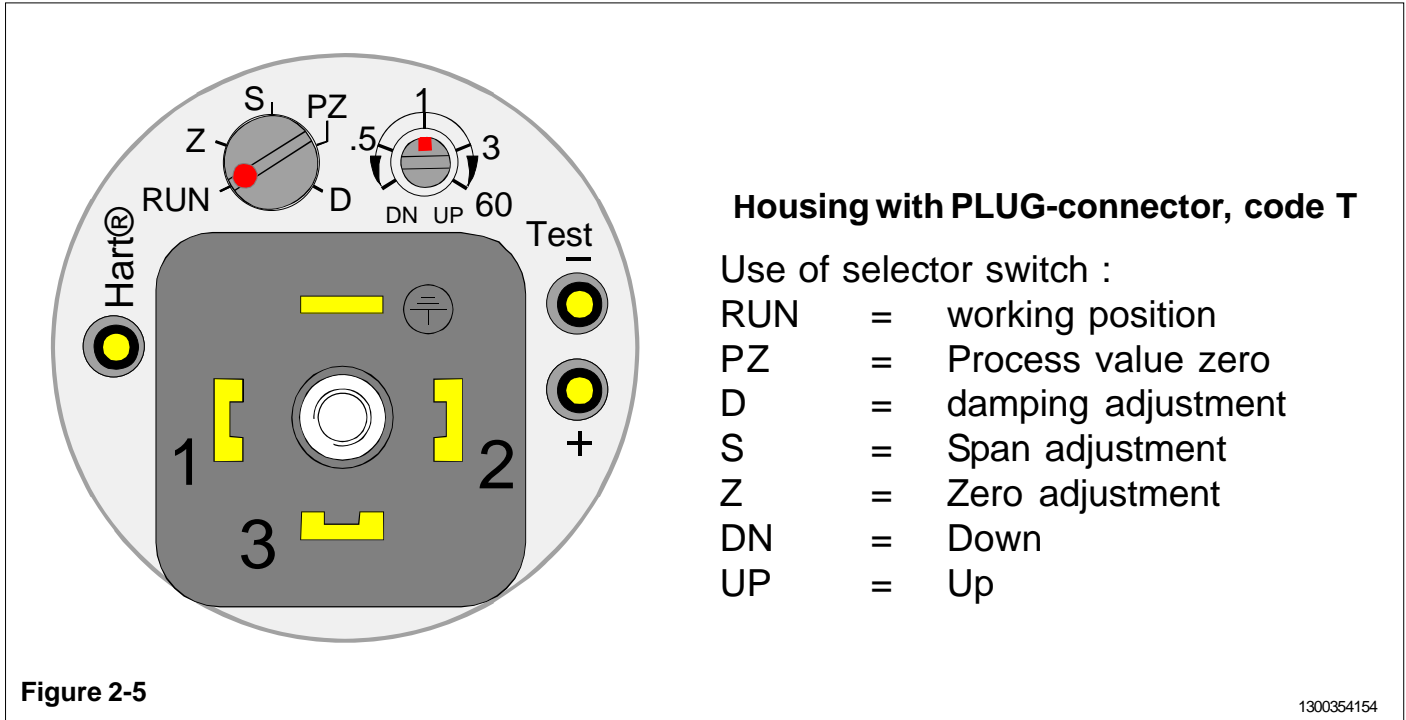


Figure 2-5

1300354154

## 3 CALIBRATION

### 3.1 Adjustability

Maximum span is 25 times the minimum span for SATRON VDtL transmitter

Span adjustments is made from outside the housing, under the protective rubber shield (figure 3-1).

### Zero suppression and elevation

Maximum zero suppression is 86 % of max.span, and maximum zero elevation is 100 % of max. span. Zero adjustments is made from outside the housing, under the protective rubber shield (figure 3-2).

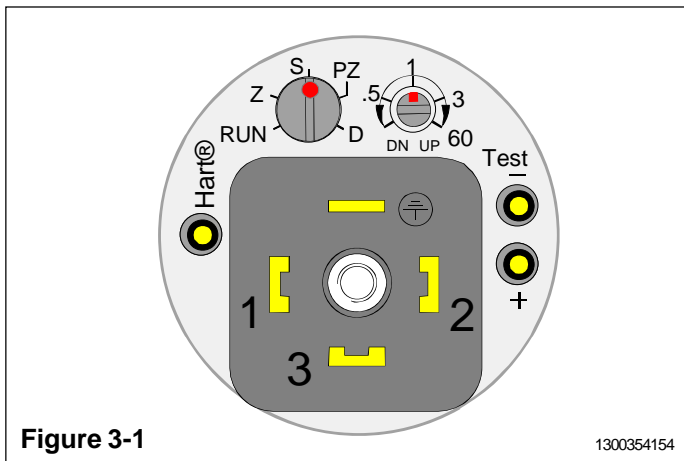


Figure 3-1

1300354154

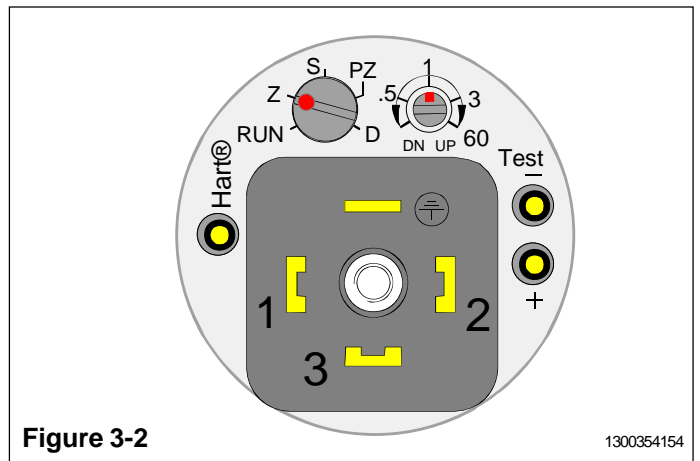


Figure 3-2

1300354154



## Measuring range

The lower and upper range-values cannot differ from zero by more than the maximum span.

For example, range 4 transmitter whose measuring range is 0-4/100 kPa cannot be adjusted to measure 100...104 kPa pressure, because maximum span is 100 kPa.

## 3.2 Damping

If pulsation occurs in the measured pressure, it can be damped with the damping trimmer position D under the protective rubber shield on the housing.

The transmitter is factory-calibrated with minimum electrical damping.

To increase the damping, turn the trimmer clockwise.

Adjusting the damping does not affect the transmitter's other calibration.

Damping adjustment :

1. Turn the selector switch from RUN to position D
2. Turn the regulating switch about  $\pm 20^\circ$  so damping adjustment is activated. Turn the regulating switch to desired value of damping. 0 s on the left side, 60 s on the right side.
3. Turn the selector switch from position D to position RUN.

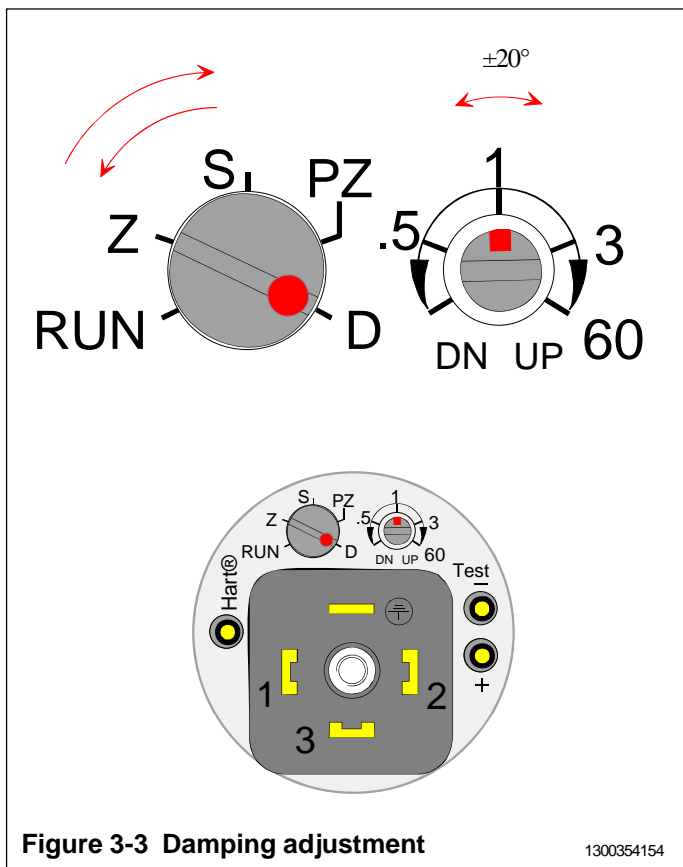


Figure 3-3 Damping adjustment

1300354154

## 3.3 Calibration examples

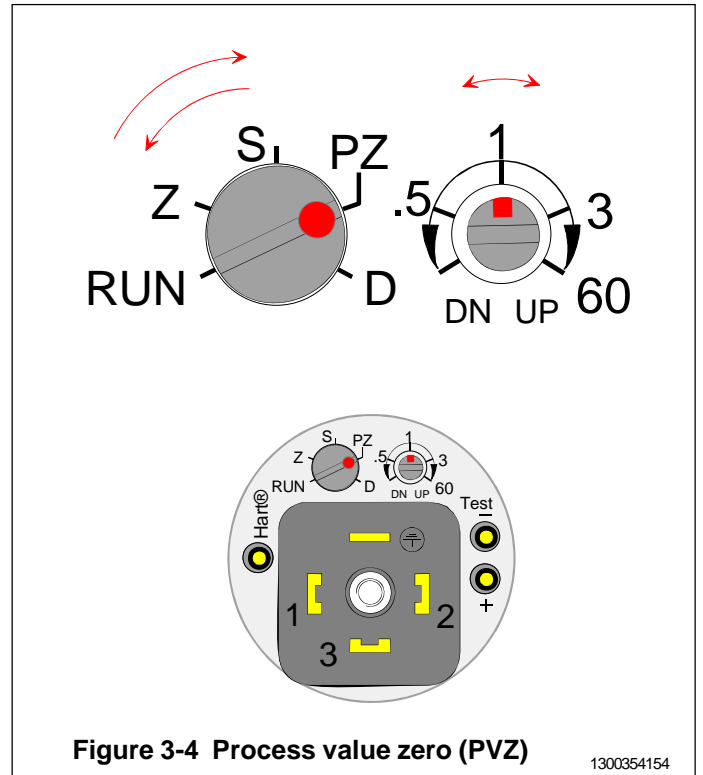
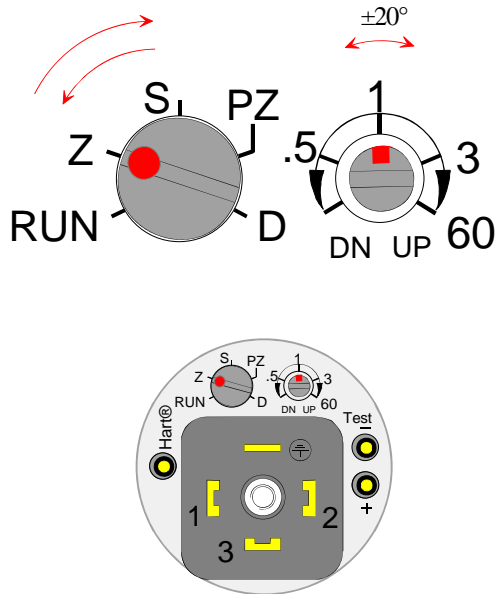


Figure 3-4 Process value zero (PVZ)

1300354154

First step is process value zero :

1. Turn the selector switch from position RUN to position PZ.
2. PV ZERO is done when the damping trimmer is turned once to both edges at least for 1 sec.
3. Turn the selector switch from position PZ to position RUN.



**Kuva 3-5 Set the lower range-value**

1300354154

Measuring range: 0...500 kPa (range 5 transmitter).

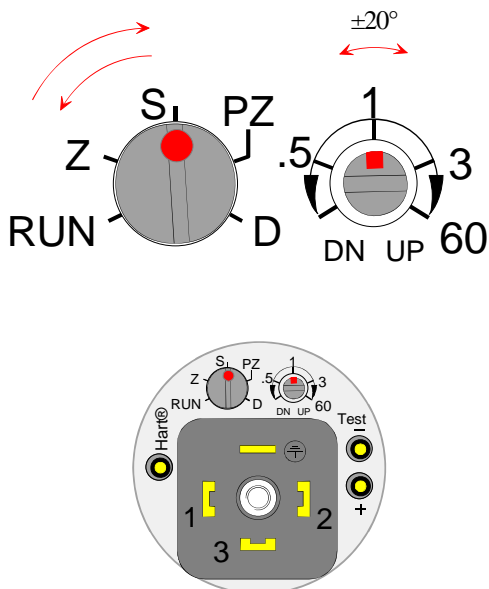
Span: 500 kPa

**Procedure**

- Apply zero pressure.
- 1. Turn the selector switch from position RUN to position Z.
- 2. Turn the regulating switch about  $\pm 20^\circ$  so adjustment is activated.
- 3. Turn the regulating switch to a point where output is closest to 4 mA. (adjustment range on fine adjustment range is  $\pm 0.75\%$  of span and speed of adjustment is  $\pm 2.5\%$  of span / s)
- 4. Turn the selector switch from position Z to position RUN.

- Apply full-span pressure.
- 1. Turn the selector switch from position RUN to position S.
- 2. Turn the regulating switch about  $\pm 20^\circ$  so adjustment is activated.
- 3. Turn the regulating switch to a point where output is closest to 20 mA. (adjustment range on fine adjustment range is  $\pm 0.75\%$  of span and speed of adjustment is  $\pm 2.5\%$  of span / s)
- 4. Turn the selector switch from position S to position RUN.

- Apply zero pressure.
- Repeat the adjustments to achieve the desired accuracy.



**Kuva 3-6 Set the upper range-value**

1300354154

## 4. CONSTRUCTION AND OPERATION

### Sensor Module

The piezoresistive sensor, which has a silicone oil fill, is isolated from the process with a diaphragm. Sensor pressure and temperature are measured with a 24-bit AD converter. Linearity and temperature effects are digitally corrected with an internal microprocessor connected to the sensor module.

The **sensor** converts pressure to electrical signal. The conversion is carried out through a Wheatstone bridge supplied with direct current. The elastic displacement produced in the bridge by the pressure causes bridge unbalance which is measured as a DC voltage signal.

**Compensation** includes temperature compensation and linearization. Each sensor is calibrated individually through a resistance network connection. The temperature information required by compensation is derived from a temperature measuring element located by the Wheatstone bridge.

### Electronics Module

The electronics module converts the process pressure signal from the sensor module to 4-20 mA output signal. The conversion can be made in linear, square root or inverted mode, or it can be done through user-selectable pressure/output point pairs (2-16 points).

Transmitters provided with own display (code **N**) is equipped with operating keys that allow you to define the transmitter's all functions.

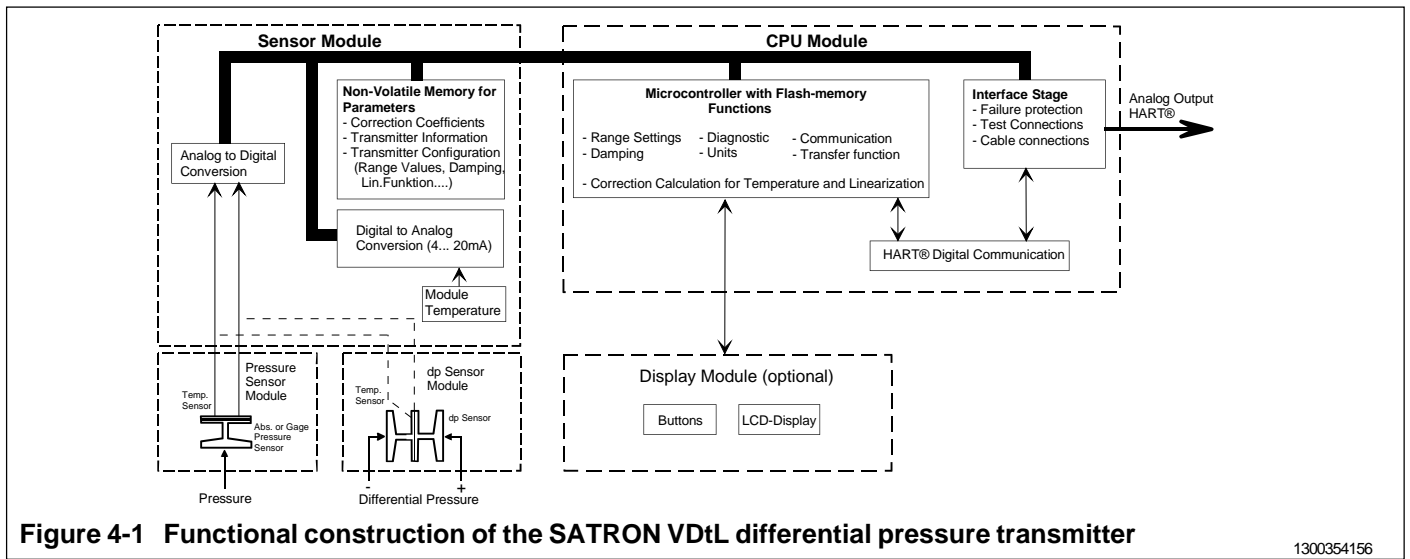


Figure 4-1 Functional construction of the SATRON VDtL differential pressure transmitter

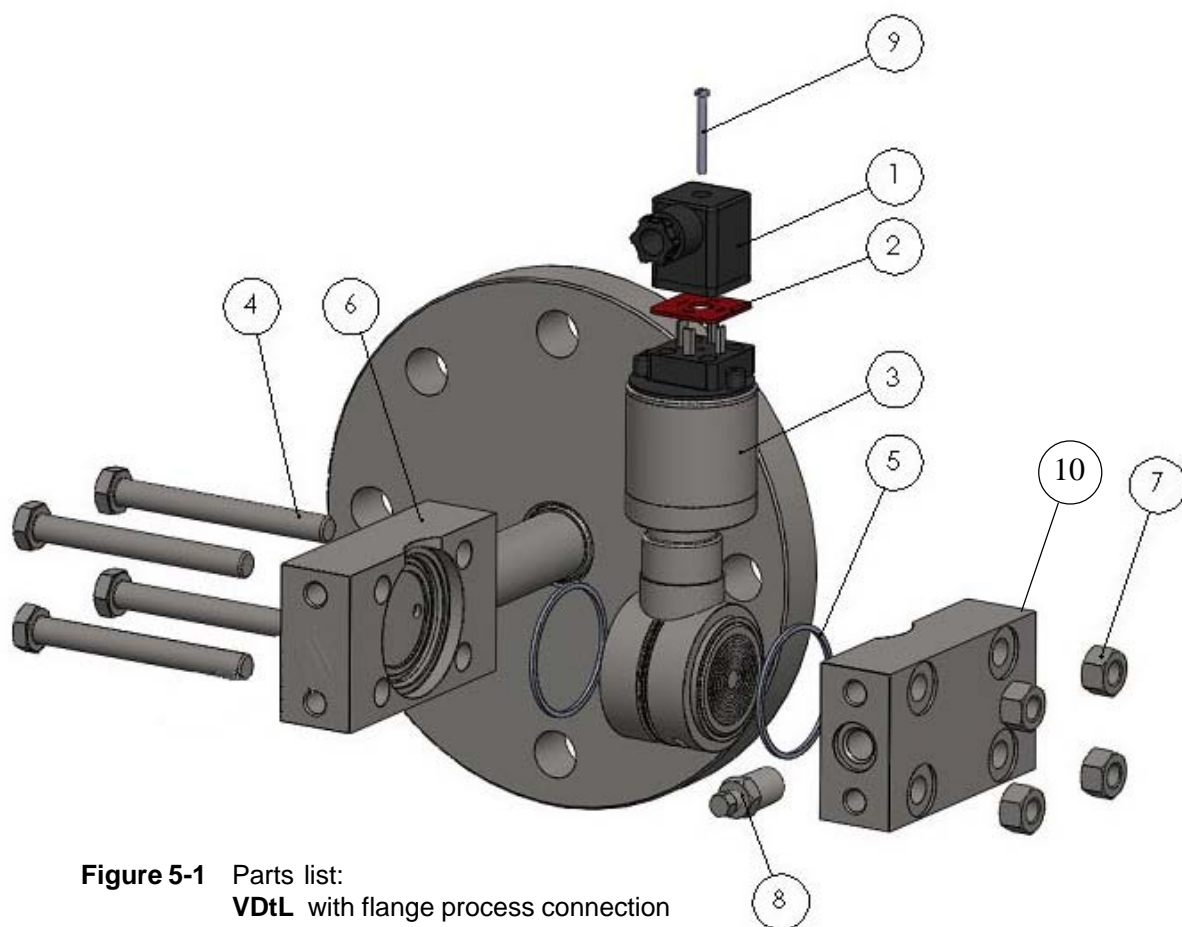
1300354156

## 5. PARTS LIST

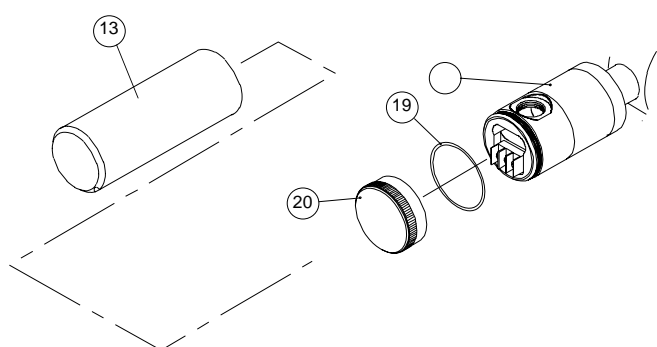
When ordering spares, please quote this document's number BLVT830AV and date 15.2.2013, the name and

order number of the required part, and the transmitter's serial number. Parts indicated with asterisk (\*) as well as screws, nuts and seals (packings) are spare parts.

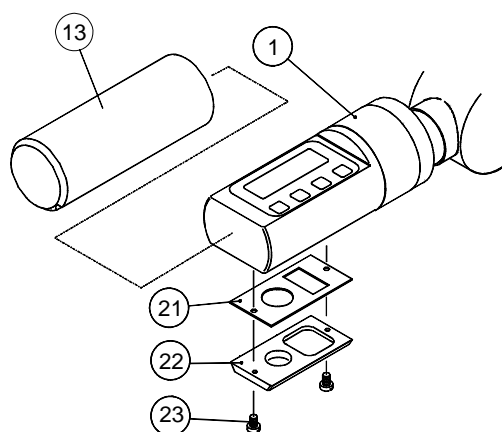
Number	Name	Order number	Number	Name	Order number
* 1	Wiring box GDM3009, DIN43650	72900111	17	Hex nut M8 SFS2067 A4	56022800
2	Seal GDM3-17, silicone	72900116	* 18	Mounting bracket S	T1050009
3	Sensing element		19	O-ring, 42x2 FPM (Viton®)	80013800
4	Hex bolt, M10x90 DIN931 A4	54228190	* 20	Cover M	T1300256
5	Seal 46/50x1.7 PTFE	T1310219	21	Seal, Silicone rubber	T1300387
6	Process connection, assembly		* 22	Back plate V	T1300391
7	Hex nut, M10 SFS2067 A4	56022810	23	Fastening screw, M4	T1325347
* 8	Vent / drain valve, ¼-NPT	T531873	35	Hex bolt M10x40 SFS2064 m A4	54228140
9	Cylinder-head screw S M3x35 SFS2179 A4	51723053	* 36	Mounting clamp NS70/76.1 SFS2333	82220000
10	Flange VDt PN100	T1310217	37	Hex nut M10 SFS2067 A4	56022810
* 13	Protection cup, housing H, M and T	T1300295	38	Seal EPDM	T1051205
* 13	Protection cup, housing N	T1300400	38	Seal FPM (Viton®)	T1051204
* 15	Mounting clamp	T544953	38	Seal PTFE	T1051203
* 16	Support plate	T543223	* 39	Coupling Sandvik 53 mm	T547290
			* 39	Coupling Sandvik 104 mm	T547291
			* 39	Coupling Sandvik 155 mm	T547292



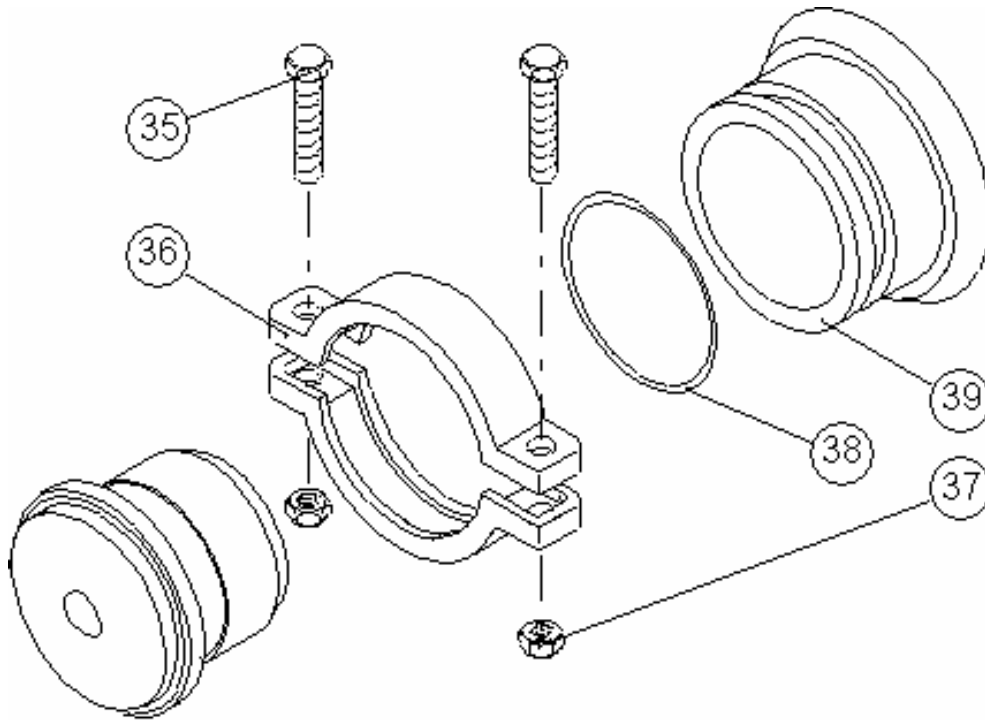
**Figure 5-1** Parts list:  
VDtL with flange process connection  
and enclosure codes H and T



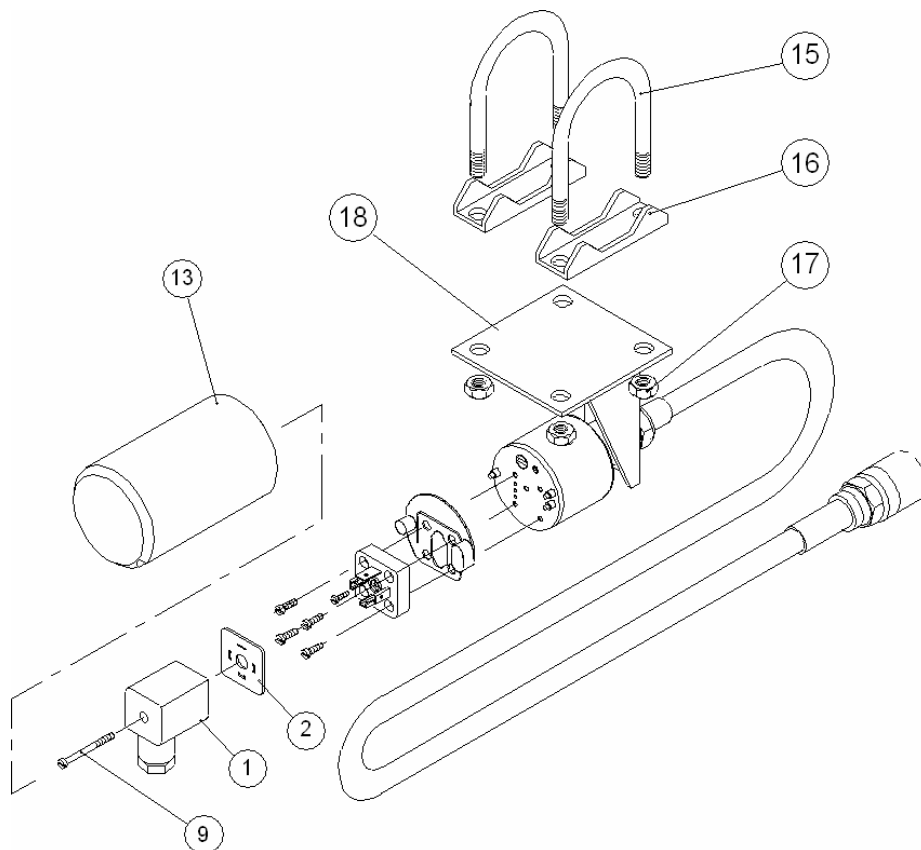
**Figure 5-2** Parts list: VDtL with enclosure code M



**Figure 5-3** Parts list: VDtL with enclosure code N



**Figure 5-4** Part list: VDtL with Sandvik-clamp process connection, code SA



**Figure 5-5** Parts list codes L and K: Mounting parts for remote electronics



**Satron Instruments Inc.**

P.O.Box 22, FIN-33901 Tampere, Finland

Tel.int. +358 207 464 800, Telefax +358 207 464 801

[www.satron.com](http://www.satron.com)