

- **Rugged Two Electrode Conductivity Sensors**
- **Unique Four Electrode Conductivity Sensors**
- **Versatile Installation Options (Threaded, Quick Change, Retractable)**
- **Specialized High Pressure / High Temperature Options**



Conductivity sensors measure the specific conductance of liquid processes. The specific conductance is directly related to the presence of ionic species and their concentration. Barben Analyzer Technology offers a full range of two electrode and four electrode contacting conductivity sensors for a variety of industrial measurement applications.

Two Electrode Conductivity Sensors

- Designed for pure water and other low to medium conductivity applications.
- Threaded in-line, submersible, and “Hot Tap” retractable product options
- Large range of cell constants to ensure the sensor range properly matches the application.

Four Electrode Conductivity Sensors

- Ideal for medium to high conductivity applications
- A great low cost alternative to toroidal sensor technology
- Additional electrode pair compensates for particulate and scale build-up.
- Threaded in-line, submersible, and “Hot Tap” retractable product options
- Sensor diagnostics (analyzer dependent)

Compatibility with All Major Vendor’s Electronics

- Proven with major vendors of conductivity analyzers (Rosemount, ABB, E&H, Mettler Toledo, Knick)
- Improve your measurement by replacing only the sensor
- Wiring information available

Industrial Mounting Options

- Mounting fittings for sample line installations
- Submersible cleaners and scrubbers
- Ball Valve “Hot Tap” retraction solutions
- Variety of materials for corrosive applications

Liquid Conductivity Two & Four Electrode Sensors

Well known for industrial pH sensor technology; Barben Analyzer Technology also provides a full range of two and four electrode industrial conductivity sensors to support your applications.

Two Electrode Sensor Technology

Two electrode sensors provide a simple, time-proven method for conductivity measurement. Precision machined electrodes of various sizes (cell constants) are matched to the process based on their measurement range. Two electrode sensors are recommended for use in clean (non-coating) applications such as the following:

- **Ultrapure Water**
- **Demineralized / Deionized Water**
- **Reverse Osmosis**
- **Water for Injection**
- **Boiler Water**

Four Electrode Sensor Technology

As the name suggests, four electrode sensors add an additional pair of electrodes to the two electrode sensor design. This second pair of electrodes provides sensor diagnostics which can then be used to compensate the measurement if scale or particulate build-up occur on electrodes. Four electrode conductivity sensors can withstand coating and scale which might otherwise foul a traditional two electrode sensor. Typical applications include the following:

- **Leak Detection**
- **Condensate Return**
- **Salinity**
- **Chemical Concentration**
- **Clean-In-Place**

Sensor Technology (How it works)

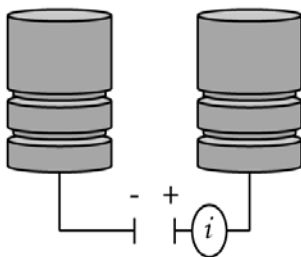

Two electrode conductivity measurement is based on the ability to conduct a current between two electrodes. The concentration of ions in the liquid are directly proportional to the conductance of the liquid.

Pros

- Simple, time-proven electrode design
- Industry standard cell constants determine measurement range.
- Works best for clean applications where electrodes do not get fouled.
- High accuracy and repeatability.

Cons

- Susceptible to coating and scale (no compensation)
- Susceptible to corrosion
- No diagnostics

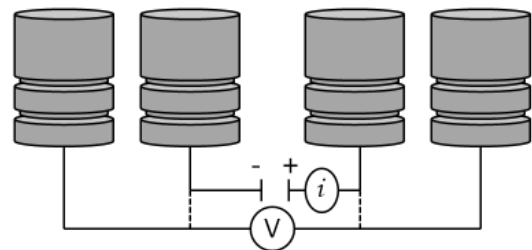

Four electrode sensor designs keep a constant current through two of the electrodes and let the drive voltage change. If fouling occurs then the drive voltage can be increased to compensate the measurement.

Pros

- Compensation for coating and build-up
- Wide measurement range
- Sensor diagnostics if fouling is too great (analyzer dependent)
- No polarization affect

Cons

- Not as accurate as two electrode sensors at low conductivity
- Susceptible to corrosion
- Limited availability of analyzers (ABB, Rosemount, Mettler Toledo, Knick)
- Conductive field can be distorted by pipe walls and flow cells

Figure 1

Liquid Conductivity Two & Four Electrode Sensors

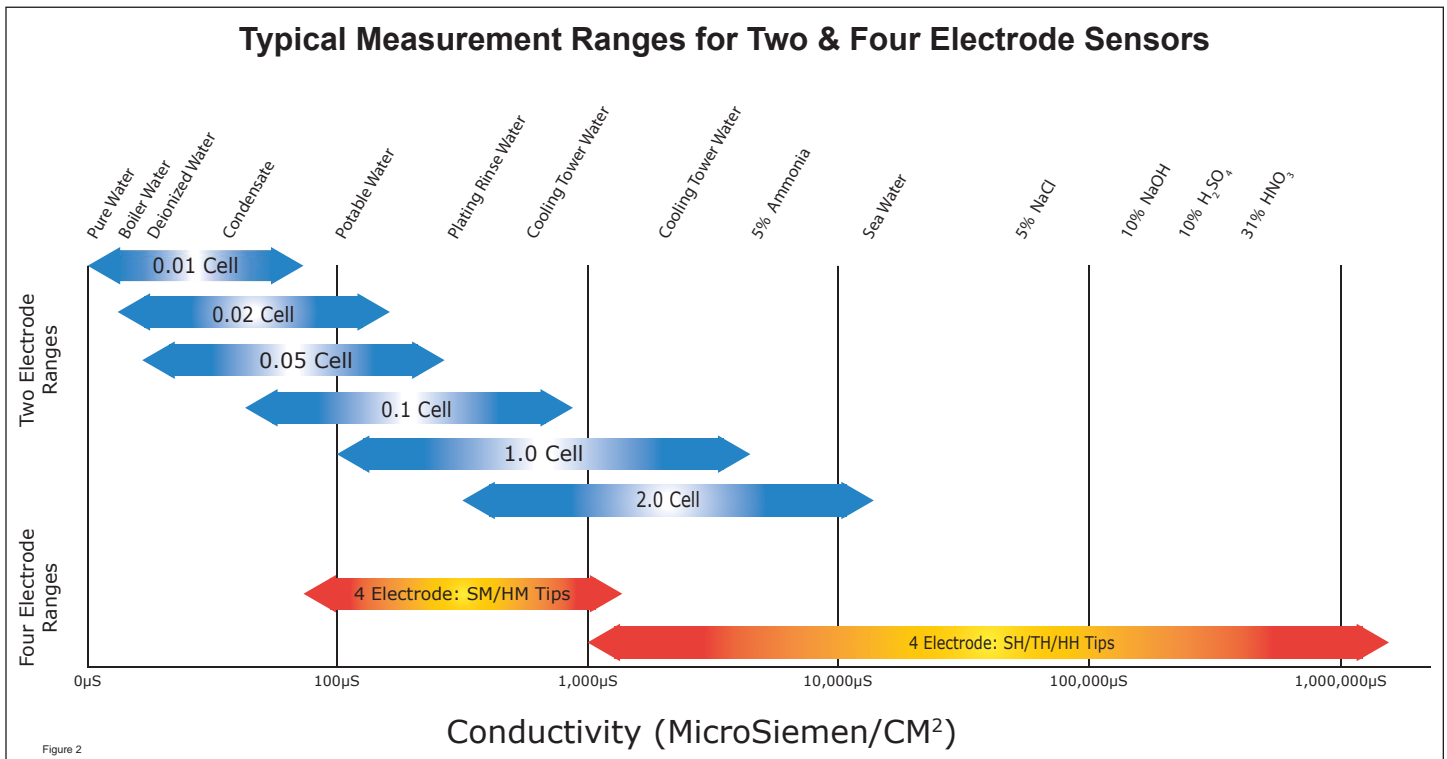

Sensor Selection: Mounting

Mounting should be considered as part of sensor selection. Examples of various process mounting configurations are provided below.

In-line Sensor Mounting: In-line installations are common on sample streams from the main process. The sensor may be mounted in a piping tee or a flow cell. The electrodes should be fully exposed to the process flow. Four Electrode Sensors require at least 1 inch of clearance from pipe walls to avoid any distortion of reading. Isolation valves should be upstream / downstream of sensor for removal.

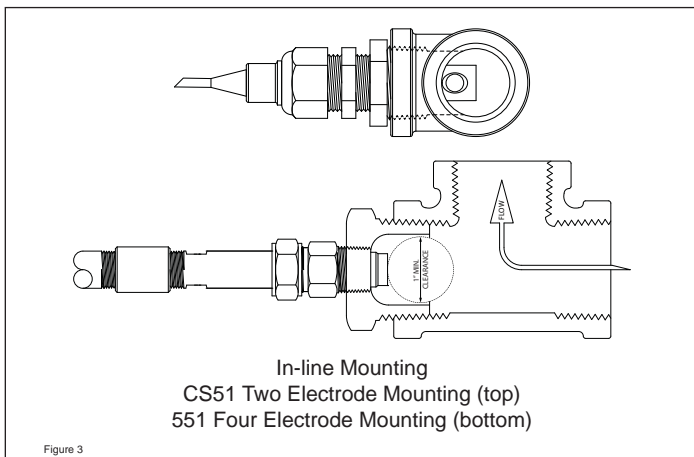

Hot Tap Sensor Mounting: Hot Tap refers to the ability to remove the sensor from the process while under pressure. A ball valve is used to isolate the sensor for removal.

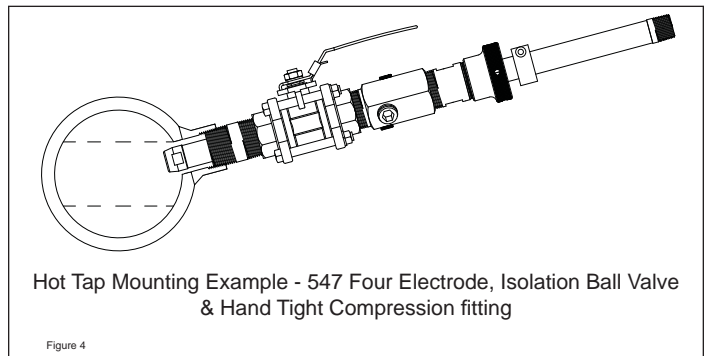

Submersible Mounting: This mounting style is used when the sensor is installed in a tank, or open channel. The sensor must be mounted on a "dip tube" which is the hardware to submerge the sensor in the application.

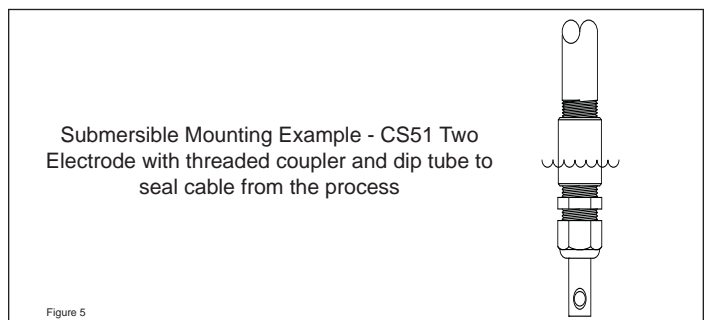

Liquid Conductivity Two & Four Electrode Sensors

Model CS10 / CS51

Two Electrode Threaded In-line, Submersible

The threaded CS10 / CS51 products are ideal for clean water sample stream applications using the NPT process connection. The same NPT adapter fitting can be reversed to mount the sensor in submersible installations.



CS10 with 0.01 Electrode

Wetted Material

- Electrodes 316 Stainless Steel
- Insulator Teflon
- Seals EPR
- Mounting Polypropylene or 316 Stainless

Temperature Compensation

- PT100 RTD
- PT1000 RTD
- 8550 Ohm (Honeywell)

Pressure / Temperature Ratings

Sensor Design	Max. Pressure / Temperature
Polypropylene Adapter	100 PSIG (690 kPa) @ 212°F (100°C)
316 Stainless Adapter	200 PSIG (1380 kPa) @ 248°F (120°C)

CS10 / CS51 Dimensions

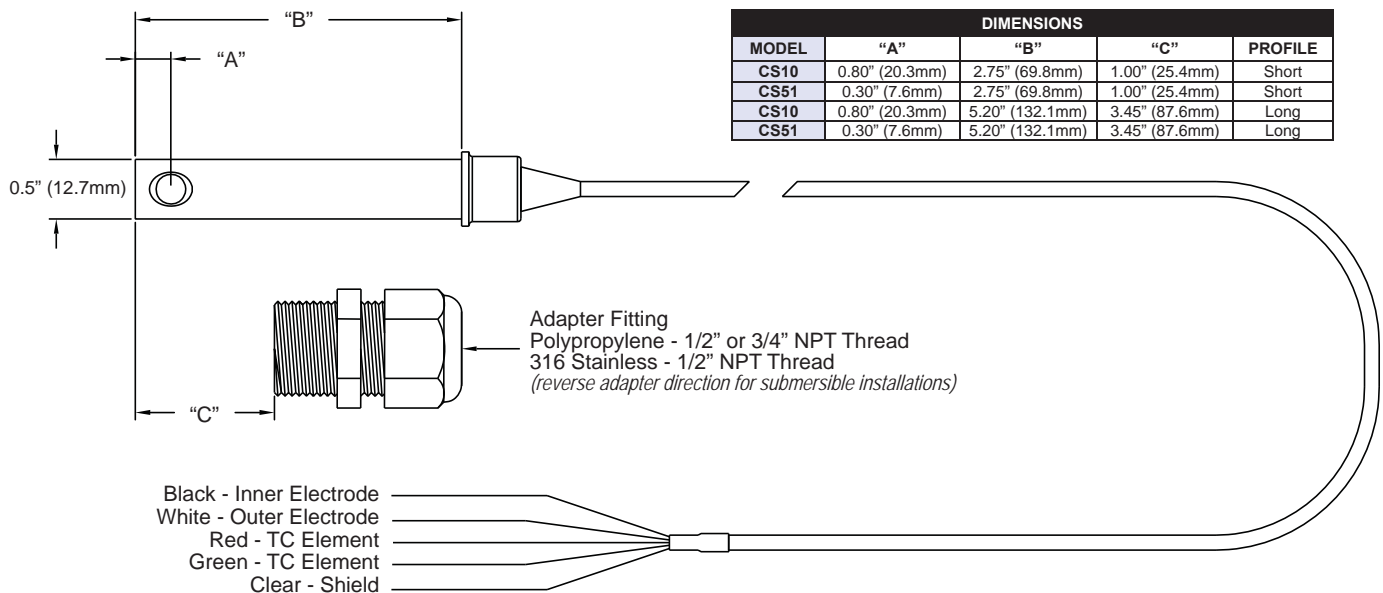

Figure 6

Liquid Conductivity Two & Four Electrode Sensors

CS10 / CS51 Two Electrode In-line / Submersible Conductivity Sensors

Body	Cell Constant	TC	Cable	Terminations	Mounting Hardware	Length	
CS10	SS316/Teflon/EPDM Inline or Submersible for Pure Waters (0.01 / 0.02 / 0.05 Cell Constant)						
CS51	SS316/Teflon/EPDM General Purpose (0.1 / 1.0 Cell Constant)						
	Cell Constant (True range is analyzer/electrode size dependant)						
	1	1.0 CS51 Only (0-20,000 MicroSiemens)					
	0.1	0.1 CS51 Only (0-1000 MicroSiemens)					
	0.05	0.05 CS10 Only (0-500 MicroSiemens)					
	0.02	0.02 CS10 Only (0-250 Microsiemens)					
	0.01	0.01 CS10 Only (0-100 MicroSiemens)					
	Integral Temperature Compensation						
		PT100	100 Ohm RTD				
		PT1000	1000 Ohm RTD				
		HW	8550 Ohm				
		(Blank)	Other				
	Cable						
		10	1 - 10 ft (whole #'s)				
		20	11 - 20 ft				
	30	21 - 30 ft					
	40	31 - 40 ft					
	50	41 - 50 ft					
	(Blank)	Other					
Lead Terminations							
	TL	All tinned leads					
	SL	All spade leads					
	(Blank)	Other					
Hardware Options for Non-Sanitary Flange							
	PP.5	1/2" MNPT Polypro Fitting					
	PP.75	3/4" MNPT Polypro Fitting					
	SS.5	1/2" MNPT SS316 Fitting					
	(Blank)	Other					
Nominal Length (reduced by sanitary flange thickness if ordered)							
	Long	5.2" (recommended)					
	Short	2.75"					
Body	Cell	TC	Cable	Terminations	Hardware	Length	
CS10	0.1	PT1000	10	TL	SS.5	Long	Typical Sensor Configuration

Liquid Conductivity Two & Four Electrode Sensors

Model CS41

Two Electrode High Pressure Threaded In-line

The CS41 Two Electrode Conductivity Sensor is specifically designed to handle the high pressure requirements found in boiler water measurement. It uses a rugged, explosionproof junction box with a high temp terminal strip for internal wiring.

Wetted Material

- Electrodes 316 Stainless Steel
- Insulator PEEK
- Seals EPR (dual o-ring)
- Mounting 316 Stainless

Pressure / Temperature Ratings

Sensor Design	Max. Pressure / Temperature
316 Stainless	400 PSIG (2758 kPa) @ 212°F (100°C) 250 PSIG (1724 kPa) @ 401°F (205°C)

CS41 with 0.10 Electrode



Temperature Compensation

- PT100 RTD
- PT1000 RTD
- 8550 Ohm (Honeywell)

CS51 Dimensions

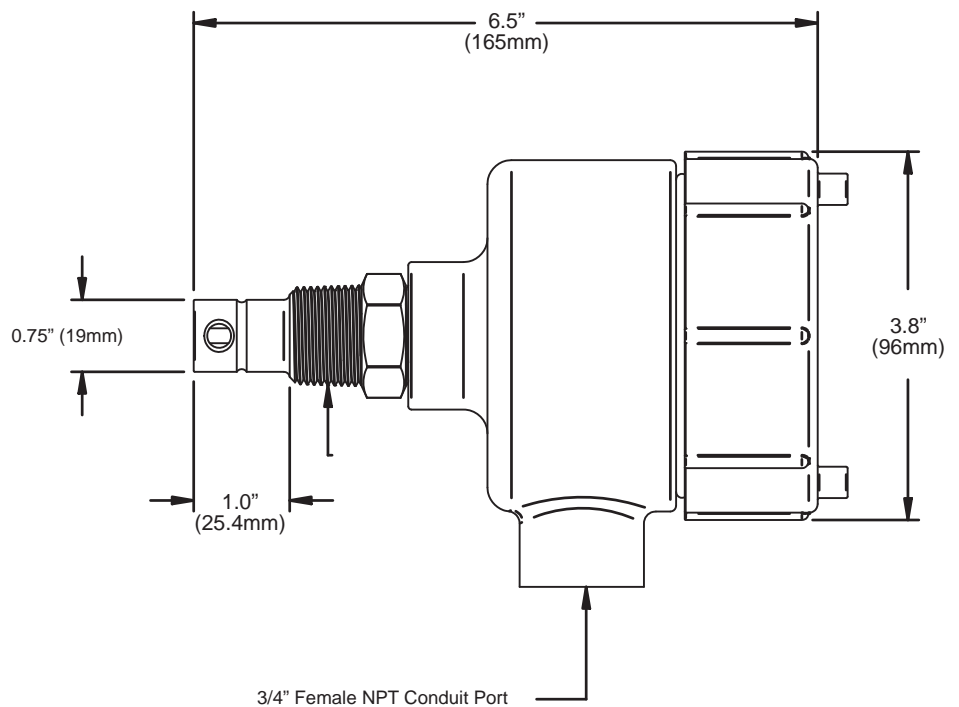

Figure 7

Liquid Conductivity Two & Four Electrode Sensors

CS41 Two Electrode High Temperature In-line Conductivity Sensors

Body	Cell Constant	Pressure / Temp	TC	Length	Cable	
CS41	SS 316 / PCTFE (Kel-F) 3/4" MNPT Inline Sensor					
	Cell Constant (True range is analyzer/electrode size dependant)					
	2	2.00 (0-30,000 MicroSiemens)				
	1	1.00 (0-20,000 MicroSiemens)				
	0.1	0.10 (0-1000 MicroSiemens)				
	0.05	0.05 (0-500 Microsiemens)				
	Pressure / Temperature Option					
	HT		High Temp. 0°C to 205°C, PEEK Insulator			
	HV		High Temp, Press, 6.5" OAL for use in 546 Hi-pressure insertion system			
	Integral Temperature Compensation					
	HW		8550 Ohm @ 25°C (Honeywell)			
	Pt100		100 Ohm @ 0°C, PTC (BAT and Others)			
	Pt1000		1000 Ohm @ 0°C, PTC (BAT and Others)			
(Blank)		Other				
Insertion Depth						
1		1.0" Insertion depth (standard)				
2.6		2.6" Insertion depth for (HV) only				
Cable						
JB		Junc Bx, Expl Proof, Inc 8" lds & Term Strip				
PT		8" Pig Tail, for Cust Supp Junc Bx Inc Term Strip				
Coup		3/4" coupling on rear of sensor				
(Blank)		Other, (Call Factory For Price & Availability)				
Body	Cell	Press / Temp	TC	Length	Hardware	
CS41	0.1	HT	PT100	1	JB	Typical Sensor Configuration

Liquid Conductivity Two & Four Electrode Sensors

Model CS40 Two Electrode Hot Tap Retractable

For applications where a sample line is not present the CS40 Two Electrode Sensor provides an easy method to remove and isolate the sensor for cleaning and calibration.

Wetted Material

- Electrodes 316 Stainless Steel
- Insulator Kel-F PCTEF (std), PEEK (high temp)
- Seals EPDM / Viton / Buna-N
- Hardware 316 Stainless

Pressure / Temperature Ratings

Sensor Design	Max. Pressure / Temperature
Standard Temp	100 PSIG (689 kPa) @ 302°F (150°C)
High Temp	250 PSIG (1724 kPa) @ 401°F (205°C)

Temperature Compensation

- PT100 RTD
- PT1000 RTD
- 8550 Ohm (Honeywell)



CS40 Dimensions

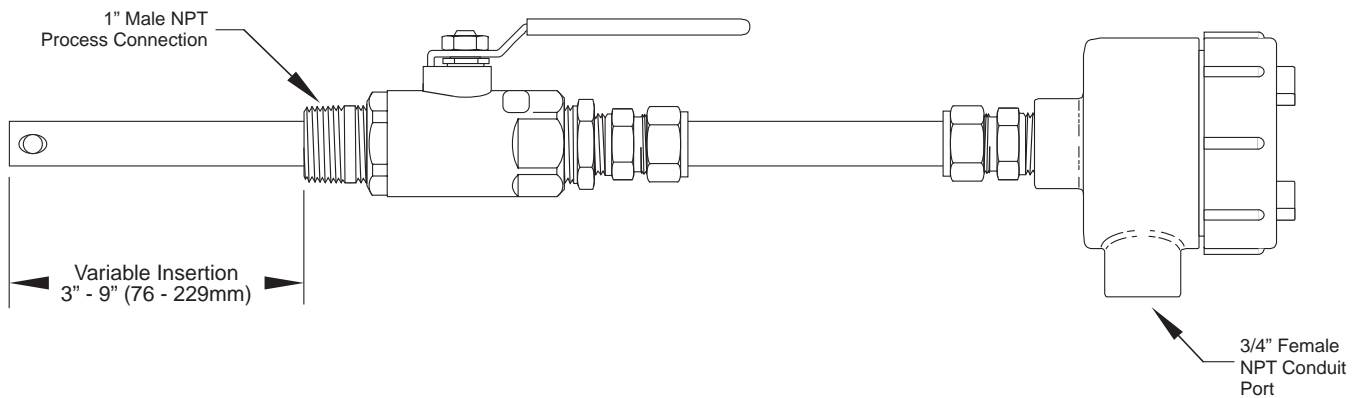

Figure 8

Liquid Conductivity Two & Four Electrode Sensors

CS40 Two Electrode Hot Tap Retractable Conductivity Sensors

Body	Orings	Cell Constant	Temp Range	TC	Cable	Terminations	Hdw	
CS40	3/4" Diameter sensor for 1" valve							
	Orings							
	S	Standard - EPDM						
	V	Viton						
	B	Buna-N						
	Cell Constant (True range is analyzer/electrode size dependant)							
	2.00	2.00 (0-30,000 MicroSiemens)						
	1.00	1.00 (0-20,000 MicroSiemens)						
	0.20	0.20 (0-2000 MicroSiemens)						
	0.10	0.10 (0-1000 MicroSiemens)						
	0.02	0.02 (0-250 MicroSiemens)						
	0.01	0.01 (0-100 MicroSiemens)						
	High Range Cell Constants							
	20.00	20.0 (0-200 MilliSiemens)						
	10.00	10.0 (0-100 MilliSiemens)						
	5.00	5.0 (0-50 MilliSiemens)						
	Operational Temperature Range							
	(Blank)	Standard up to 150°C, PCTFE Insulator						
HT	Hi-Temp. 205°C Max, PEEK Insulator (Not Avail for High Range Constants)							
Integral Temperature Compensation								
HW	8550 Ohm @25°C, (Honeywell)							
Pt100	100 Ohm @0°C, PTC (BAT and Others)							
Pt1000	1000 Ohm @0°C, PTC (BAT and Others)							
(Blank)	Other							
Cable								
JB	Junc Box, Exp Proof, Inc 8" Leads & Term							
PT	8" Pig Tail, Inc Term Strip							
10	Footage 1-10Ft (Whole Numbers Only)							
20	Footage 11-20Ft							
30	Footage 21-30Ft							
40	Footage 31-40Ft							
50	Footage 41-50Ft							
(Blank)	Other							
Lead Terminations								
TL	All Tinned Leads							
SL	All Spade Lugs							
(Blank)	Other							
Hardware								
SSV	1" SS Ball Vlv, Cmp Ftg & Nip							
N	None							
(Blank)	Other							
Body	Orings	Cell Constant	Temp Range	TC	Cable	Terminations	Hdw	
CS40	S	0.1		PT100	10	TL	SSV	Typical Sensor Configuration

Liquid Conductivity Two & Four Electrode Sensors

Model 551 / 546 / 547

Four Electrode In-line, Hot Tap, and Submersible

Barben's four electrode conductivity sensors use the same housing and accessories as our pH products.

Wetted Material

- Electrodes 316 Stainless, Titanium Gr2, Hastelloy C
- Insulator PEEK
- Seals EPDM / Viton
- Hardware *(see accessories guide for hardware options)*

547 Cartridge style Four Electrode Sensor



Temperature Compensation

- PT100 RTD
- PT1000 RTD
- 3K Ohm RTD (Balco)

Pressure / Temperature Ratings

Sensor Type	Installation Type		
	Threaded Nut Lock (plastic / metal body with hand nut only)	Threaded Nut Lock (metal body & metal hex nut only)	Flanged / Threaded Nut Lock (plastic body & metal hex nut only)
551	100 PSIG @ 158°F (70°C) 40 PSIG @ 212°F (100°C)	300 PSIG @ 176°F (80°C) 40 PSIG @ 266°F (130°C)	150 PSIG @ 73°F (25°C) 25 PSIG @ 266°F (130°C)

Sensor Type	Installation Type	
	3/4" In-line or Submersible*	High Pressure Hot Tap
546	150 PSIG @ 158°F (70°C) 40 PSIG @ 266°F (130°C)	300 PSIG @ 176°F (80°C) 40 PSIG @ 266°F (130°C)

Sensor Type	Installation Type	
	Threaded In-line High Pressure	Retractable
547	2500 PSIG @ 122°F (50°C) 50 PSIG @ 266°F (130°C)	150 PSIG @ 158°F (70°C) 40 PSIG @ 266°F (130°C)

Four Electrode Tip Options

HIGH RANGE ELECTRODES (0 - 2 SIEMENS) SH, TH, HH SERIES



Metal Electrodes
316SS, Titanium, Hastelloy C
Dual EPDM or Viton O-ring Seals

Flush High Range Electrodes



LOW RANGE ELECTRODES (0 - 1400 MICROSIEMENS) SM, HM SERIES



Metal Electrodes
316SS, Hastelloy C
Dual EPDM or Viton O-ring Seals

Extended Low Range Current Electrodes

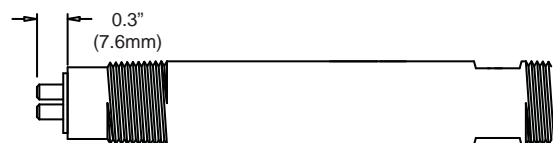
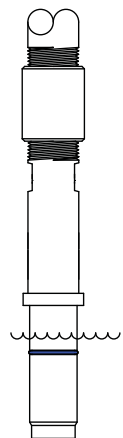

Figure 9

Liquid Conductivity Two & Four Electrode Sensors

551 Four Electrode Conductivity Sensor



Example - 551 Sensor
Submersible installation

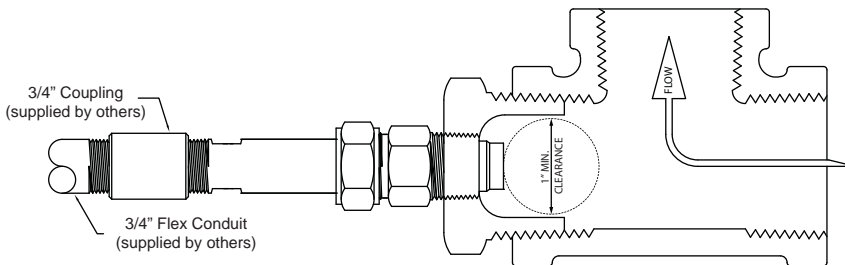
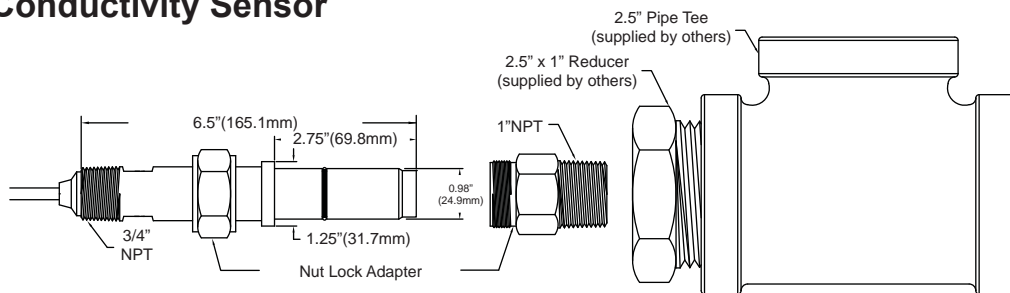

The full offering of mounting adapters and flowcells used with the 551 sensor can be found in the Barben Accessories Guide (Consult technical support for more information)

546 Four Electrode Conductivity Sensor

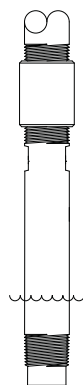

Example - 546 Sensor
Submersible installation

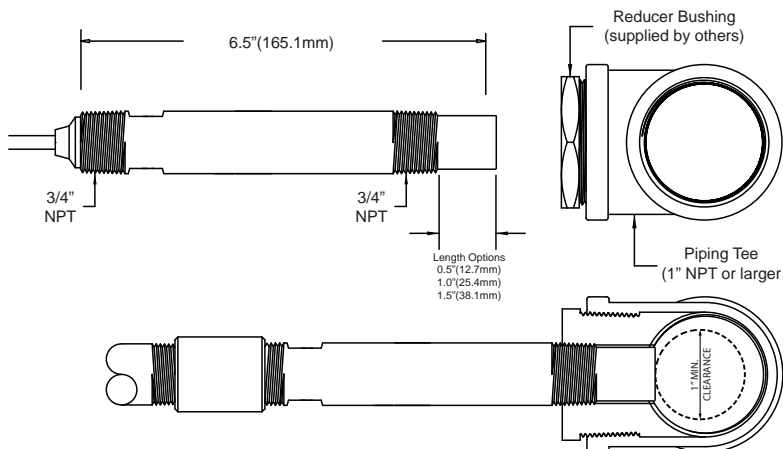

Flow cells and other accessories used with the 546 sensor can be found in the Barben Accessories Guide (Consult Barben technical support for more information)

547 Four Electrode Conductivity Sensor

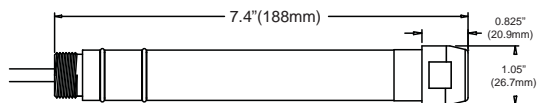

Bottom image show 547 sensor with hot tap retractable hardware Barben offers an extensive offering of compression fittings, valve assemblies and sheath kits. These can be found in the Barben Accessories Guide (Consult Barben technical support for more information)

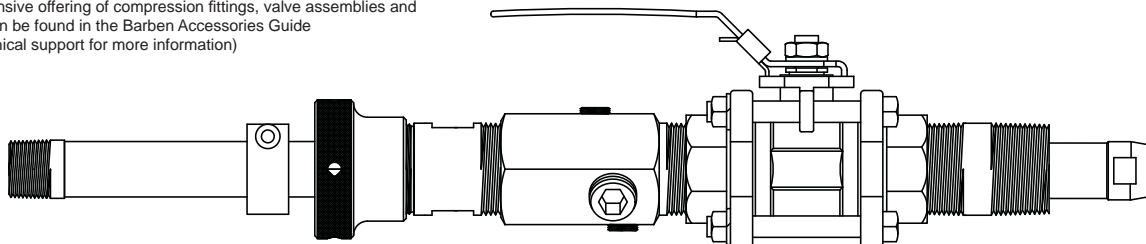

Figure 10

Liquid Conductivity Two & Four Electrode Sensors

551 / 546 / 547 Four Electrode Conductivity Sensors

Material	Orings	Body Style	Electrodes	TC	Insertion Depth	Cable	Terminations	
B	Kynar body PEEK insulator							
Seals								
E		EPDM						
V		Viton						
Configuration								
551		Quick-Change Inline (Drawing 2P0076)						
546		Threaded In-line / Submersible 3/4" NPT (Drawing 2P0078)						
547		Cartridge for Valve Insertion (Drawing 2P0079)						
Electrode Range and Material (True range is analyzer dependant)								
SM		0 - 1,400 MicroSiemens - SS 316, 0.0275 cell constant						
SH		0 - 2 Siemens - SS 316, 0.3727 cell constant						
TH		0 - 2 Siemens - Titanium Gr2, cell constant 0.3727						
HM		0 - 1,400 MicroSiemens - Hastelloy C, 0.0275 cell constant						
HH		0 - 2 Siemens - Hastelloy C, 0.3727 cell constant						
Integral Temperature Compensation								
K		PT1000						
C		PT100						
B		3K Ohm Balco (120°C Max)						
(Blank)		Other						
Insertion Depth								
S		551 / 547 Standard						
0.5		546, 1/2"						
1		546, 1"						
1.5		546, 1-1/2"						
(Blank)		Other 546 special order, (0.5" Increments), 5.0" Max						
Cable								
T		8" Pigtail for (Junction Box 546/551)						
T1		8" Pigtail for (8" assy 547 or High Pressure 547)						
T2		8" Pigtail for (16" 547 assy)						
T3		8" Pigtail for (20" 547 assy or 546 Hot Tap)						
T4		8" Pigtail for (24" 547 assy)						
T5		8" Pigtail for (30" 547 assy)						
T6		8" Pigtail for (36" 547 assy)						
T7		8" Pigtail for (60" 547 assy)						
1 to 5		Footage 1 - 5'						
6 to 20		Footage 6 - 20'						
21 to 30		Footage 21 - 30'						
31 to 40		Footage 31 - 40'						
41 to 75		Footage 41 - 75'						
76 to 100		Footage 76 - 100'						
Lead Terminations								
T		All Tinned						
S		All Spades #6						
Material	Orings	Body Style	Electrodes	TC	Insertion Depth	Cable	Terminations	
B	E	547	SM	C	S	5	T	Typical Sensor Configuration

Barben Analyzer Technology reserves the right to make technical changes or modify the contents of this document without prior notice. We reserve all rights in this document and in the subject matter and illustrations contained within.

Hastelloy® is a registered trademark of Haynes Intl Inc.
 Kalrez® and Viton are registered trademarks of DuPont Dow Elastomers L.L.C.
 Kynar® is a registered trademark of Elf Atochem North America Inc.
 Teflon® is a registered trademark of E.I. DuPont de Nemours Company Inc.