



INSTRUCTION MANUAL

KS

PULP SAMPLERS

Warnings

WARNINGS!

Keep fingers out from the sampling piston.

Keep fingers out from the moving parts.

Make certain that before installation or removal of the sampler, the process pipe is empty and depressurized.



Table of contents

1. Introduction.....	4
1.1. Contact information.....	4
1.2. Recommendations for sampling.....	4
1.3. Safety.....	4
2. Models and applications.....	5
2.1. KS/2.....	5
2.1.1. KS/2 - Manual sampler.....	6
2.1.2. KS/2 - Pneumatic sampler.....	6
2.2. KS/4 - Pneumatic sampler.....	7
2.3. KS/6 - Pneumatic sampler.....	8
2.4. Installation location.....	9
2.5. Process connections.....	10
2.5.1. Installation with clamp connection.....	10
2.5.2. Installation with thread connection.....	10
2.6. Installation of pneumatic operating valve.....	11
2.7. Installation of sampling detector.....	11
3. Sampling.....	12
3.1. Sample flow adjustment.....	12
Appendix 1: Installation welding instructions.....	14
Appendix 2: Explosion drawings.....	189
Appendix 3: Recommended spare parts.....	26
Appendix 4: Specifications.....	27

1. Introduction

1.1. Contact information

Europe, Asia and South America:	North America:	Japan:
Kajaani Process Measurements Ltd.	Kajaani Process Measurements Inc.	KajaaniProcess Measurements Ltd.
PO BOX 94	636 U.S. Route 1, Box # 4	4-444-5 Nishimiyashita
FI – 87101 Kajaani, Finland	Scarborough, ME 04074, U.S.A	Ageo-shi, Saitama-Ken, Japan
Tel: +358 8 633 1961	Tel: +1 207 883 1095	Tel: +81 48 776 7695
Fax: +358 8 612 0683	1 800 consist (266 7478)	Fax: +81 48 776 8469
E-mail: kpm@prokajaani.com	Fax: +1 207 883 1104	E-mail: k.doi@prokajaani.com
	E-mail: kpmusa@prokajaani.com	

Please find your local supplier on internet address www.prokajaani.com

1.2. Recommendations for sampling

Safe and representative sampling is the base for laboratory analyses.

Flushing of the sampler is important to prevent some pulp get dry inside the sampler and block the sampling for next sample.

Sampling:

Allow some pulp to flow to sewer

Scoop sample into the sample cup from sample flow without overflowing.

Flush sampling valve with water.

1.3. Safety

Sample outlet may be hot or there might be steam in the sample which **may cause skin burns**.

Process pressure might be high and the sample may come out very fast.

Sample outlet should be directed so that sample area stays clean. It is recommended to make funnel where sample hose comes. Funnel should have drain and water flushing.

Samples flow rate should be adjusted in pneumatic models. Piston stroke length can be adjusted so that sample flow rate is not too high.

Hose connection **should always be done, because otherwise spills are possible from the sampler outlet. Manual sampling should be done carefully so that hands are not exposed to hot spills.**

2. Models and applications

Accurate and representative laboratory result is very important for transmitter calibration. These sample valves are designed for representative and safe sampling.

Flushing water connection ensures to clean the valve. Flushing eliminates clogging and pulp to dry inside sampler.

Pneumatic model helps the operation and ensures similar sampling each time.

Process connection can be saddle or thread mounting.

There are three different models available based on application.

2.1. KS/2

KS/2 model is designed for screened pulps only. No shives nor trash is allowed. Consistency range is 0 – 8 %Cs. There exists manual and pneumatic model.

Manual model operates by pulling handle outwards from the sampling valve. Closing is supported by spring. There is no stroke length adjustment in manual model.

Pneumatic model is operated by pneumatic operating valve. Stroke length can be adjusted.

KPM	
Sampler type	Description
KS/2 sampler for screened pulps 0-8%Cs, no knots or shives	
KS/2 -	
M	Manual
P	Pneumatic actuator ø40mm (1 1/2")
S	NS40 Sandvik clamp
T	NPT1 1/2" thread
S	Wetted parts material AISI316
T	Wetted parts material Titanium
S	Process coupling material AISI316
T	Process coupling material Titanium
N	No process coupling
H	Hose outlet 38mm (1 1/2")
P	Pneumatic operating valve assy 6mm(1/4") connectors
N	No operating valve
C	Sampling detector
N	No sampling detector
Note1 ! Water connection NPT1/4" (compatible R1/4")	
Note2! Manual models: Sampling detector is inductive switch 24...48VDC	
Pneumatic models: Sampling detector is reed relay switch 24VDC or 100VAC (not 220VAC)	
Example types	
KS/2 -	M S S S H N N
KS/2 -	M T S S H N N
KS/2 -	P S S S H P N
KS/2 -	P T S S H P N
KS/2 -	P S T T H P N
KS/2 -	P T T T H P N

2.1.1. KS/2 - Manual sampler

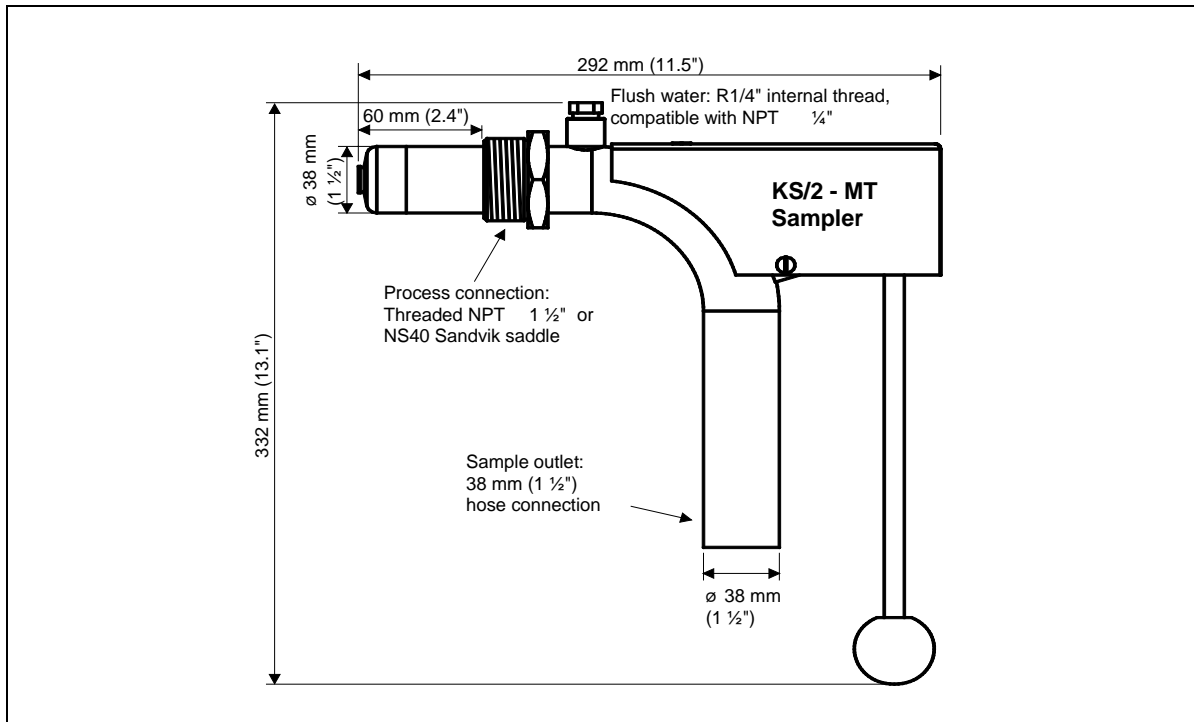

Figure 2.1. KS/2 - MT.

2.1.2. KS/2 - Pneumatic sampler

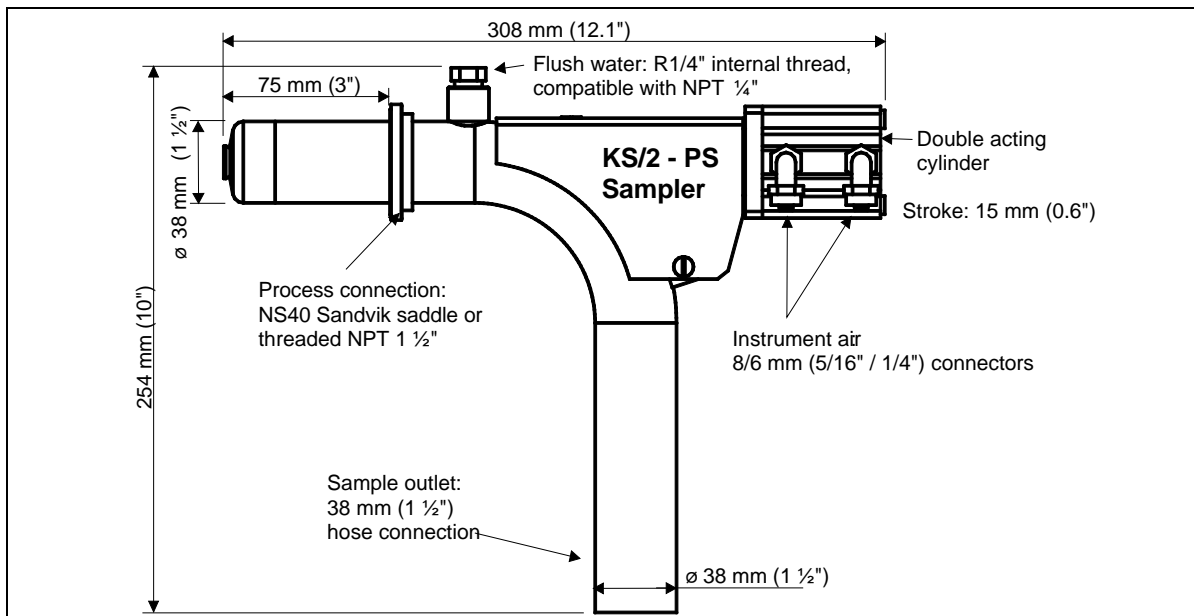

Figure 2.2. KS/2 - PS.

2.2. KS/4 - Pneumatic sampler

KS/4 model is designed for unscreened pulps where shives and trash can be present. Knots are too large particles for this model. Piston has a cutting edge, which helps the piston close tight even though there are shives in the sample. Consistency range is 0 - 8%Cs.

KPM	
Sampler type	Description
KS/4 sampler for unscreened pulps 0-8%Cs	
KS/4 -	P S T S N H F P N C N
	Pneumatic actuator $\varnothing 63$ (2 1/2")
	NS40 Sandvik clamp
	NPT1 1/2" thread
	Wetted parts material AISI316
	Process coupling material AISI316
	No process coupling
	Hose outlet 38mm (1 1/2")
	Flanged outlet 38mm (1 1/2") for welded hard pipe
	Pneumatic operating valve assy 8mm(5/16") connectors
	No operating valve
	Sampling detector
	No sampling detector
Note! Water connection R1/2" (compatible NPT1/2")	
Note! Sampling detector is reed relay switch 24VDC or 100VAC (not 220VAC)	
Example types	
KS/4 -	P S S S H P N
KS/4 -	P S S S F P N
KS/4 -	P T S S H P N

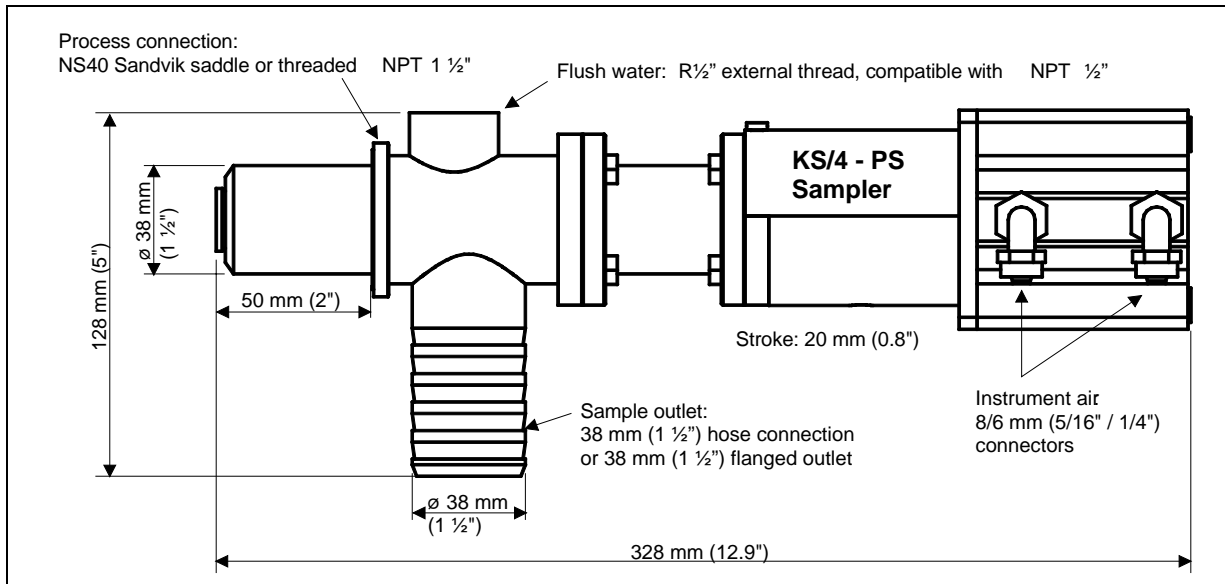

Figure 2.3. KS/4 - PS.

2.4. Installation location

Best location is always on straight piece of pipeline, never in elbows nor corners. Choose the installation location best suited for the application as displayed in figures 2.4 and 2.5. Respect minimum process pressure specifications (see appendix 4).

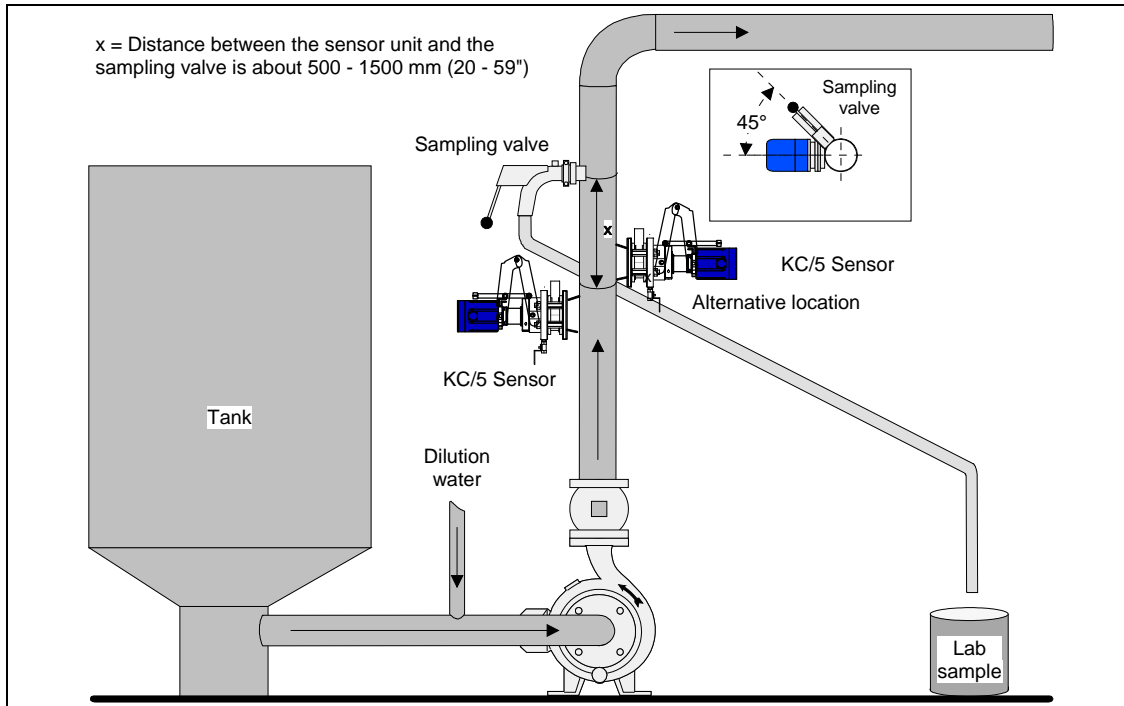

Figure 2.5. Installation in the vertical pipe.

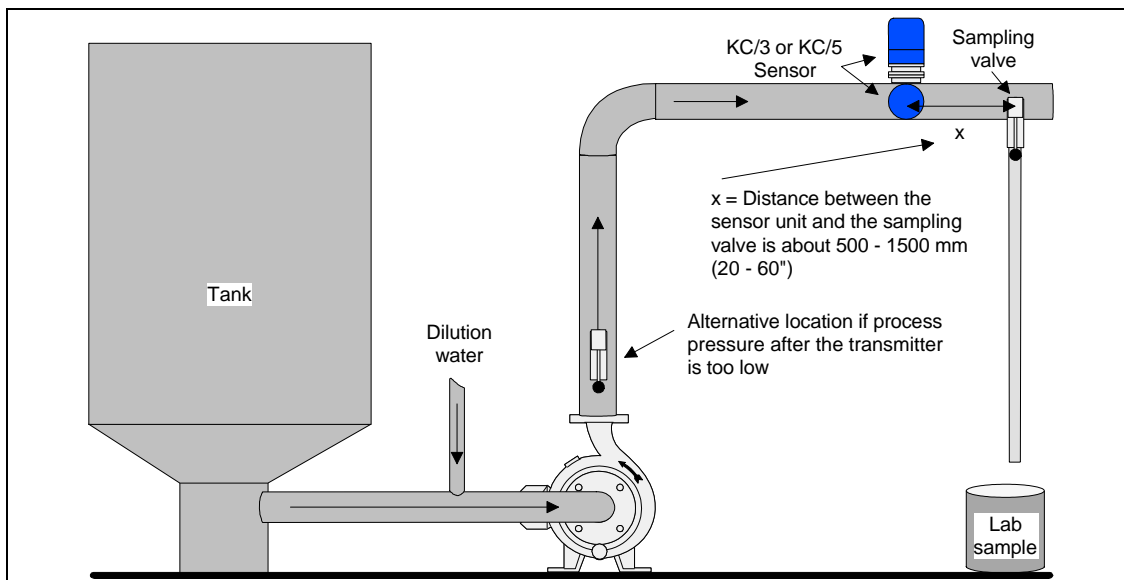

Figure 2.6. Installation in the horizontal pipe.

2.5. Process connections

Make sure that before installation or removal of the sampler the process pipe is empty and depressurized. Look welding drawings in Appendix 1.

NS40 Sandvik saddle for KS/2 and KS/4: Drawing H41070050V1.0

Threaded 1½” NPT for KS/2 and KS/4: Drawing H41070049V1.0

NS70 Sandvik saddle for KS/6, process pipe AISI316 PN10 (ANSI150): Drawing H41070046V1.0

NS70 Sandvik saddle for KS/6, process pipe AISI316 PN25 (ANSI300): Drawing E31010107V1.0

NS70 Sandvik saddle for KS/6, process pipe Titan PN25 (ANSI300): Drawing E31010108V1.0

2.5.1. Installation with clamp connection

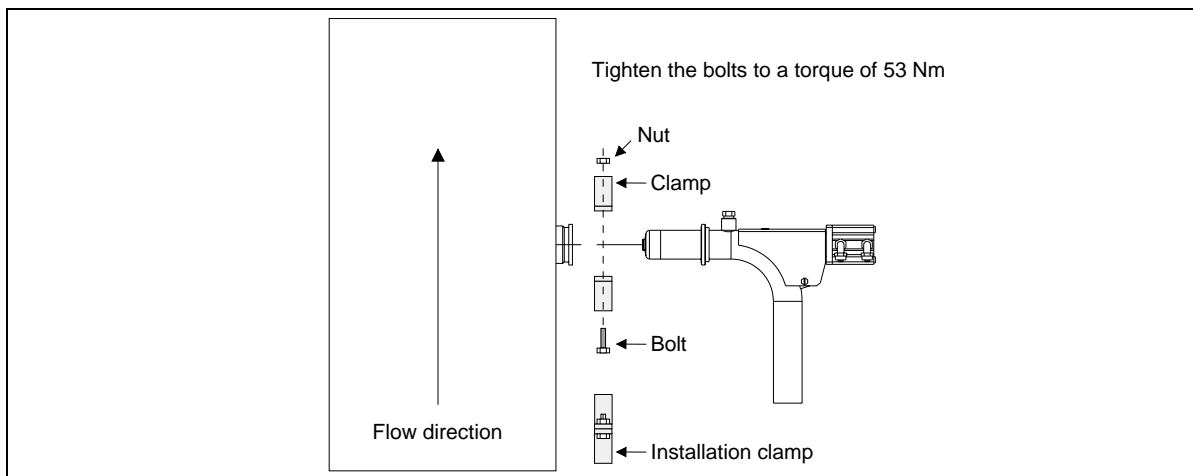

Figure 2.7. Installation with saddle connection.

2.5.2. Installation with thread connection

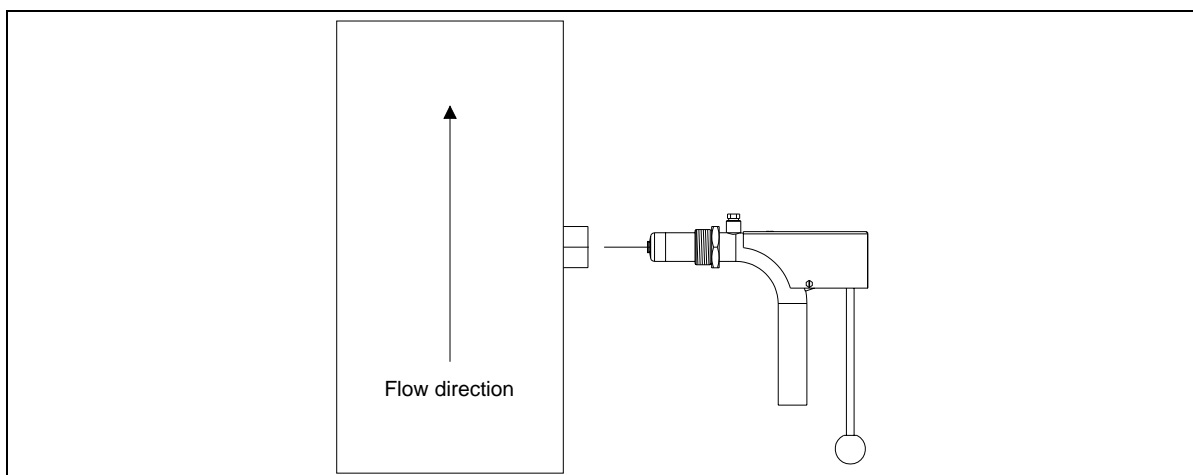

Figure 2.8. Installation with thread connection.

2.6. Installation of pneumatic operating valve

This valve is used for remote control of sampling for pneumatic models (See fig 2.9).

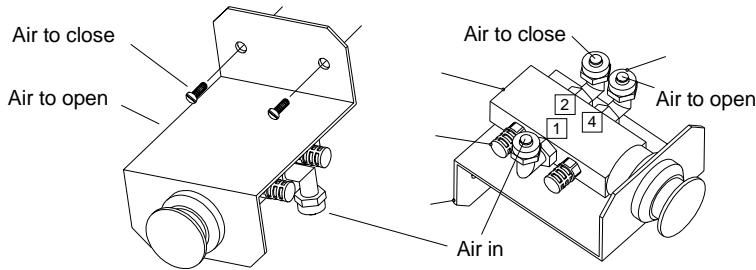

Figure 2.9. Installation of pneumatic operating valve.

2.7. Installation of sampling detector

Electric position switch of sampling piston (sampling detector) is used for stamping the time in the DCS or in transmitter. This is feedback to DCS of successful sampling. Sampling detector needs external power supply 24VDC or 110VAC (not 230VAC) and can be installed by sliding it to the slot in cylinder. Fixing in to the bottom position will be done by fixing screw (See fig 2.10).

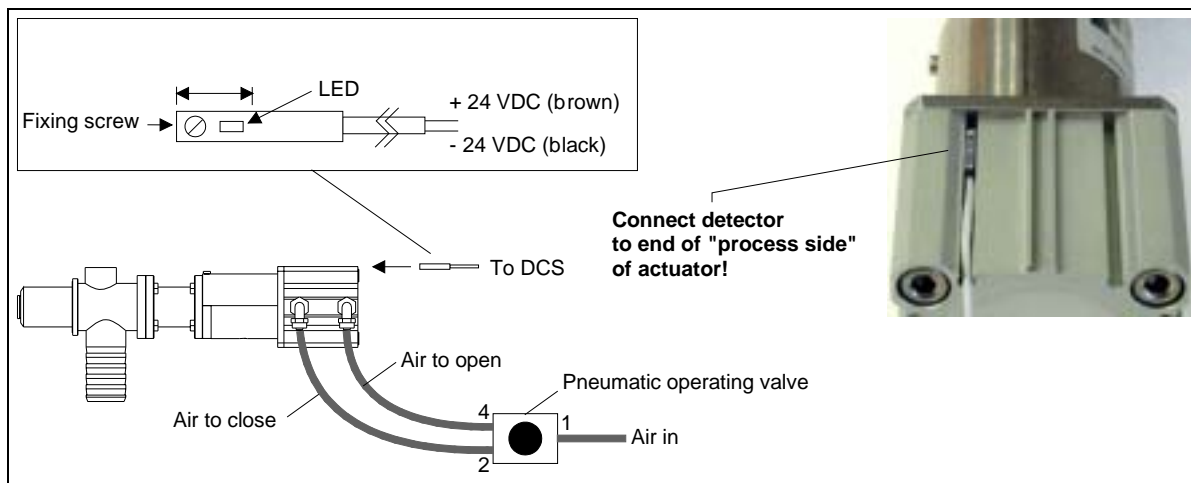

Figure 2.10. Installation of sample detector (electric position switch).

3. Sampling

3.1. Sample flow adjustment

KS/2-M

In manual model the handle movement controls the sample volume. Pulling the handle more out from the sampler causes larger sample volume. Opening only little the sample valve may cause filtration of sample and the sampling is not representative.

KS/2-P

In pneumatic model the stroke length can be adjusted by turning the pneumatic cylinder closer or further from the sampling piston. Adjust stroke length so that sample flow is proper.



Figure 3.1. KS/2-P stroke length adjustment.

KS/4-P

Stroke length can be adjusted by Stroke Length Adjustment Nut. Default setting is for maximum stroke length.

To decrease stroke length

loose **Locking screw** (3 mm allen)

slide **Setting ring** towards the piston.

turn **Stroke length adjustment nut** towards the piston (19 mm wrench)

after length adjustment push **Setting ring** towards cylinder as far it goes

tighten Locking screw.

Tighten Stroke length adjustment screw towards the piston.

Piston direction adjustment is made by turning piston shaft by using 13 mm wrench.

Default setting is opening facing downwards. Piston opening should not be against process flow.

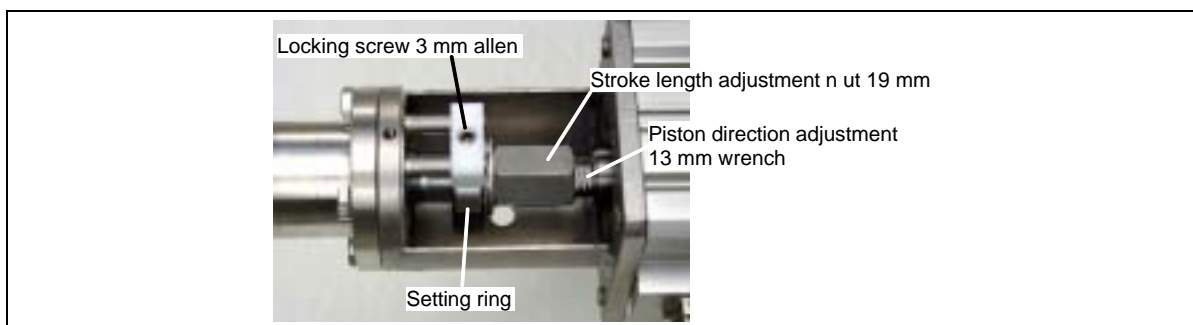

Figure 3.2. KS/4 stroke length adjustment.

KS/6-P

Stroke length can be adjusted by limiting the pneumatic cylinder movement. Default setting is for maximum stroke length. Decreasing stroke length can be done by turning two **Adjustment Bolts**, which limits **Setting Ring** movement.

Piston direction adjustment is made by turning piston shaft by using 22 mm wrench. Default setting is opening facing downwards. Piston opening should not be against process flow

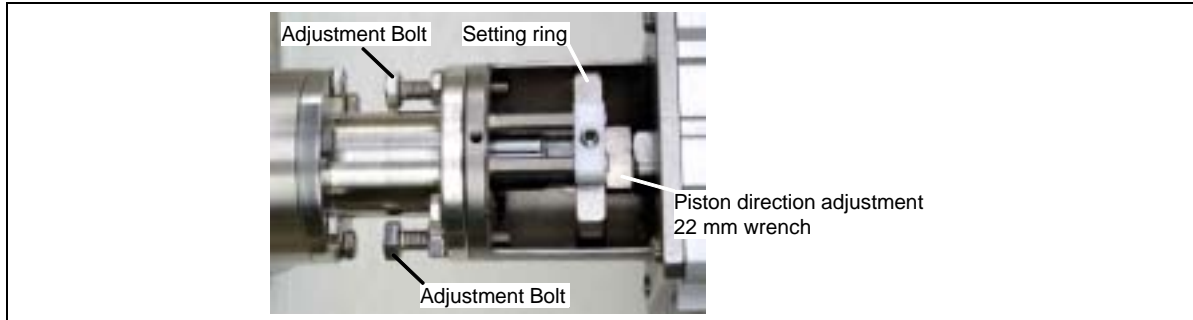

Figure 3.3. KS/6 stroke length adjustment.

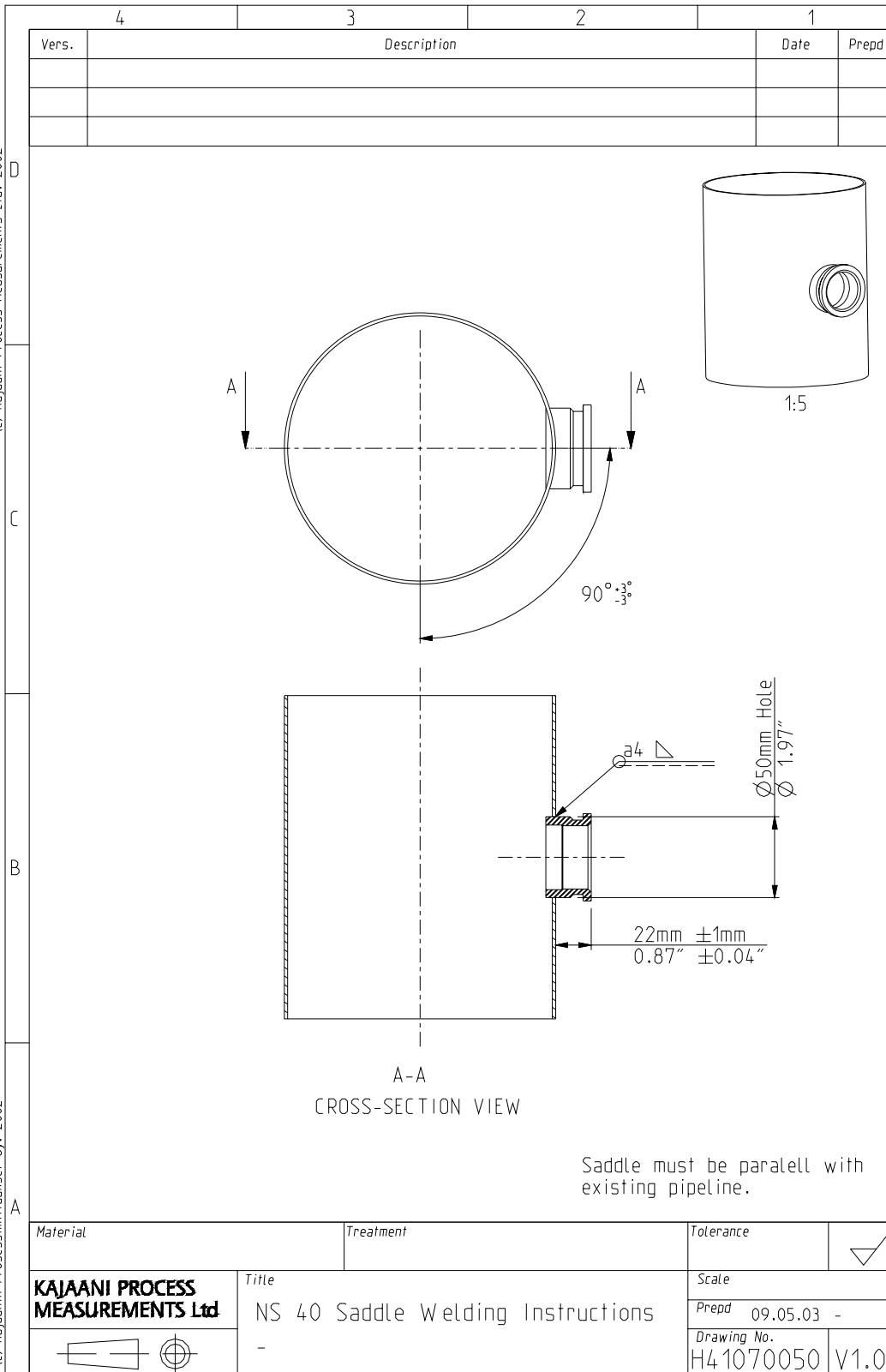

Figure 3.4. KS/6 stroke limited by bolts. Piston is out in this position.

Appendix 1: Installation welding instructions

This document must not be copied without our written permission, and the contents thereof must not be imparted to a third party or be used for any unauthorized purpose.
 (C) Kajaani Process Measurements Ltd. 2002

Tätä asiakirjaa ei saa ilman meidän lupaamme jäljentää. Sitä ei myöskään saa esittää toiselle tai muuoin asiattomasti käyttää.
 (C) Kajaani Prosessimittaukset Oy. 2002





This document must not be copied without our written permission, and the contents thereof must not be imparted to a third party or be used for any unauthorized purpose. (c) Kajaani Process Measurements Ltd., 2002

Tämä asiakirja ei saa ilman meidän lupamme, jäljentää, siirä ei myöskään saa esittää toiselle tai muutoin asiain-
mastr. Käyttää. (c) Kajaaniin Prosessimittaukset Oy. 2002

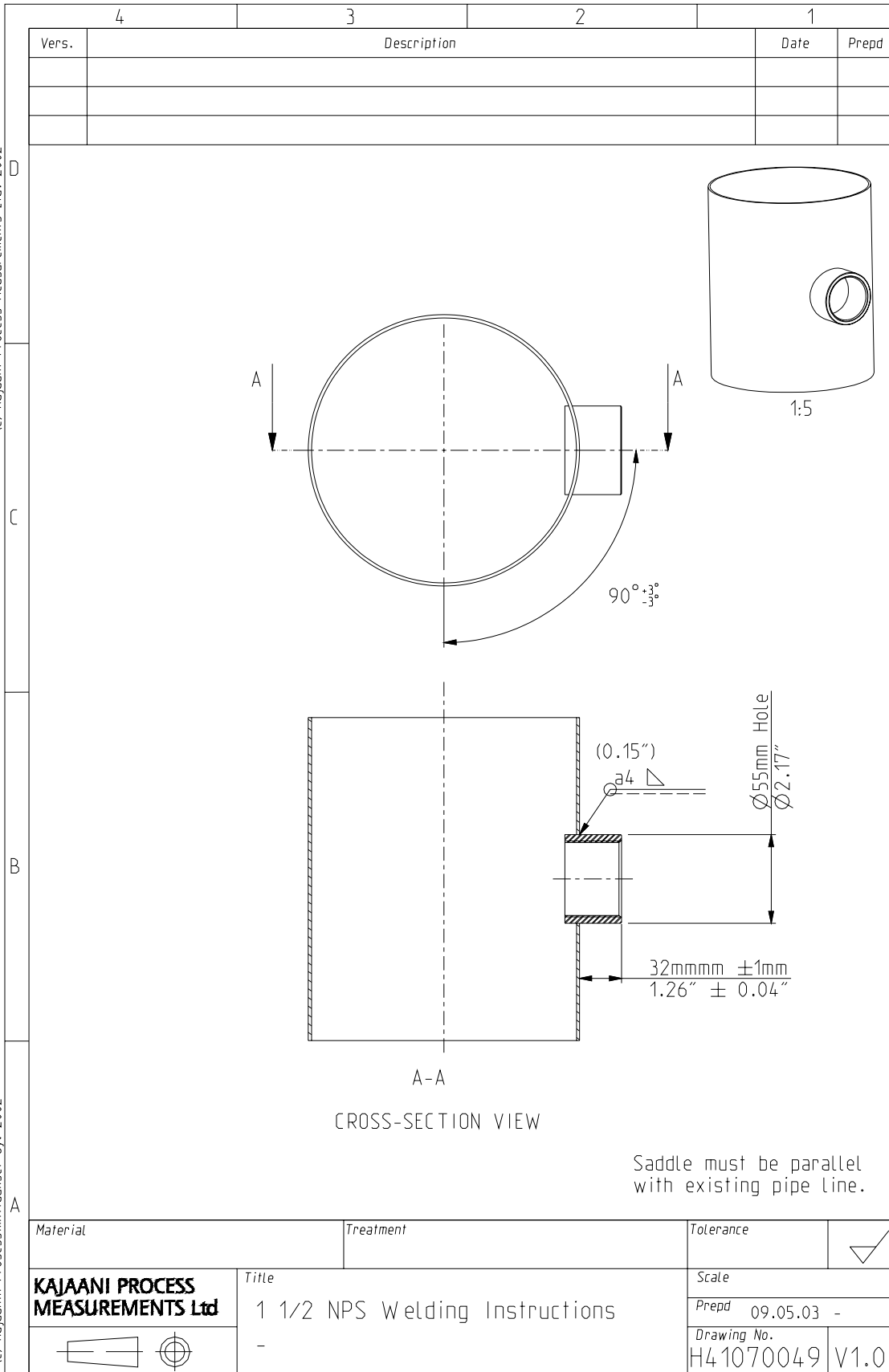



This document must not be copied without our written permission, and the contents thereof must not be imparted to a third party or be used for any unauthorized purpose. (c) Kajaani Process Measurements Ltd., 2002

Tämä asiakirja ei saa ilman meidän lupamme, jäljentää, siirä ei myöskään saa esittää toiselle tai muutoin asiain-
maisiin käyttää. (c) Kajaaniin Prosessimittaukset Oy, 2002

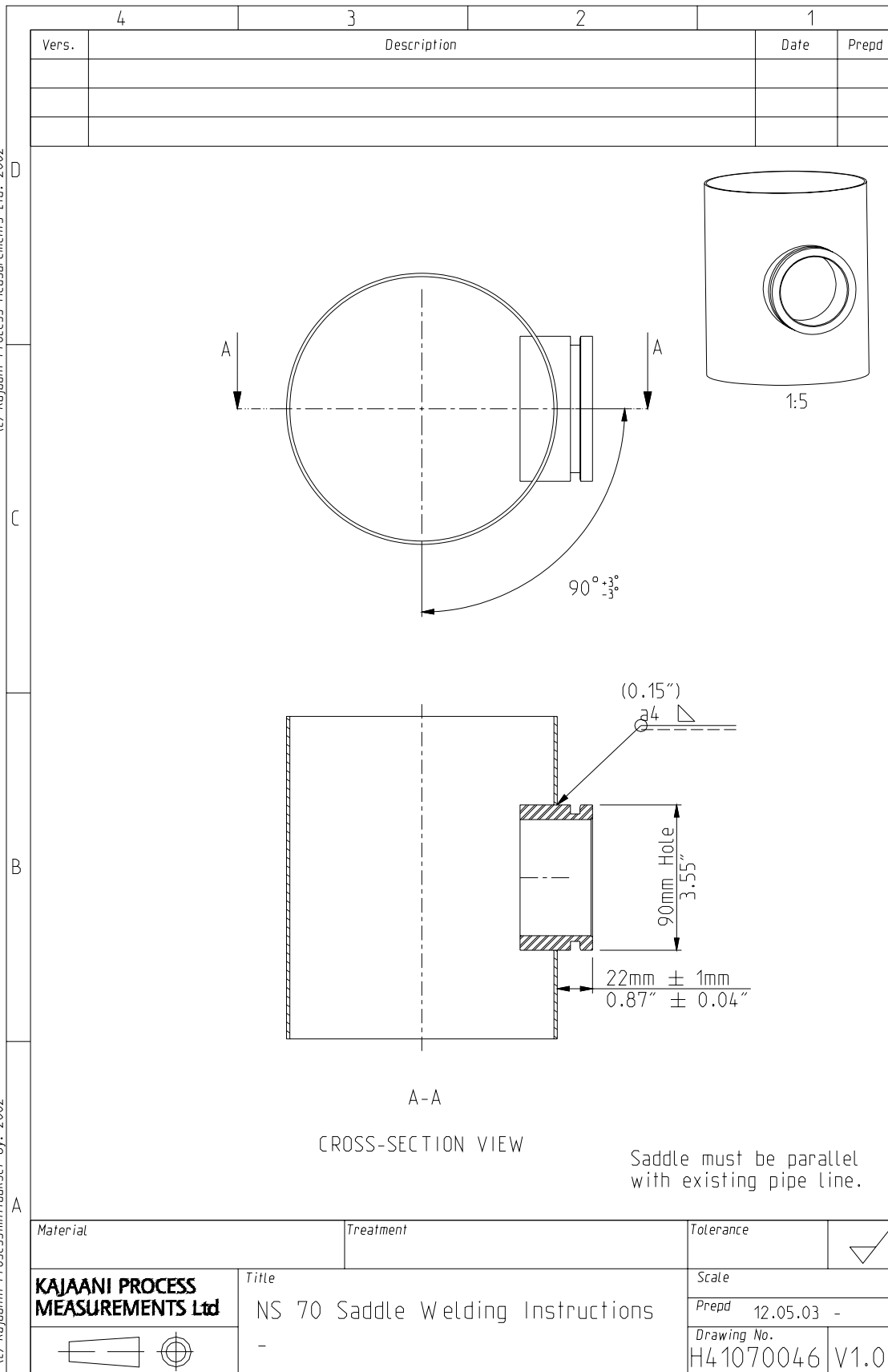

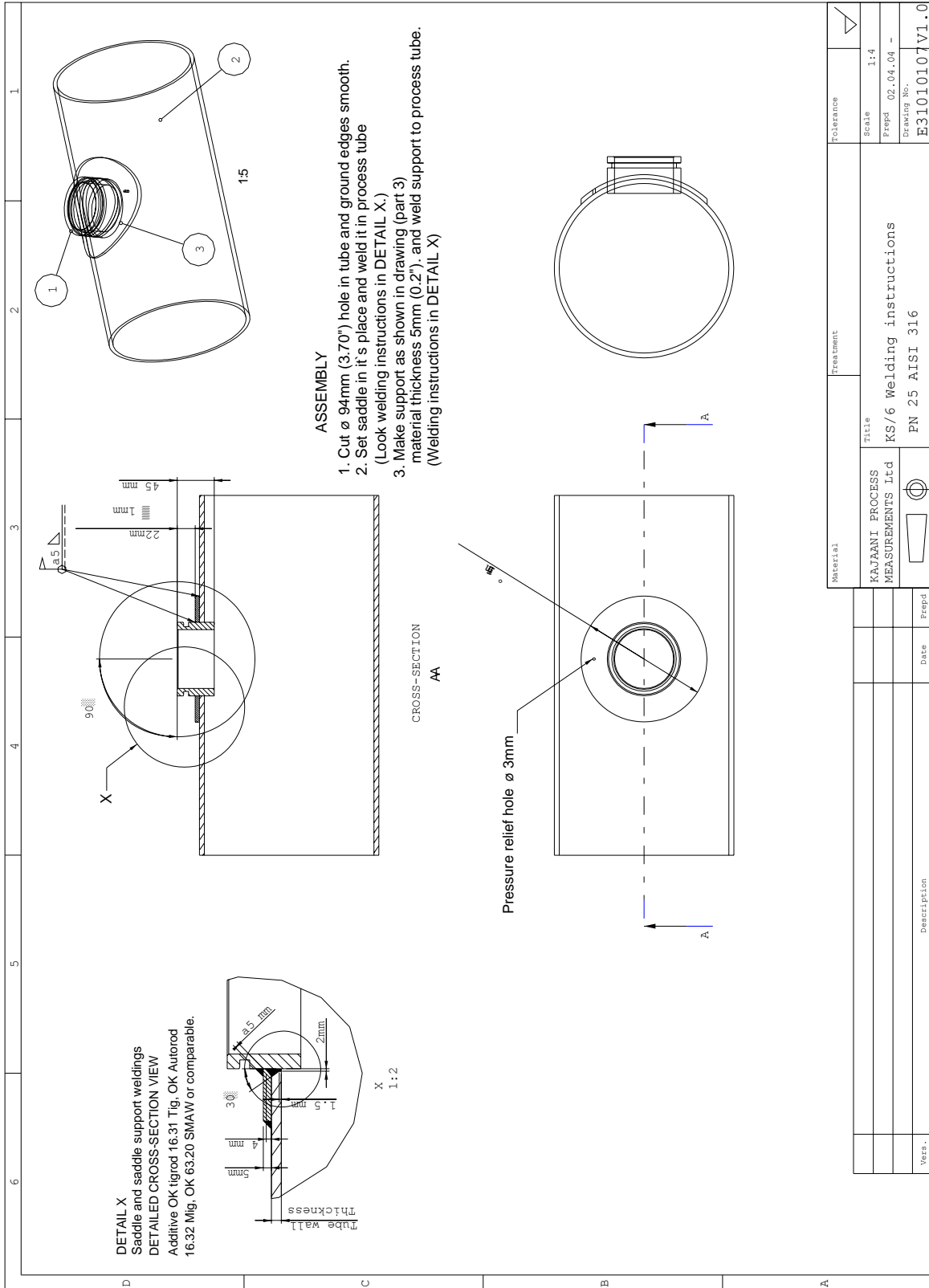

Toto asiakirja ei saa liian meidnpuame jolienoh. Sit ei myskoon saa eistoh tosalitel muutoin alatto. (c) Kajaani Process Measurements Oy, 2002. This document must not be copied without our written permission, and the contents thereof not be imparted to a third party or be used for unauthorized purposes. (c) Kajaani Process Measurements Ltd, 2002

Material	Treatment	Polerance	
KAJAANI PROCESS MEASUREMENTS Ltd		Title	KS/6 Welding instructions
PN 25 AISI 316		Prepd	02.04.04 -
Vers.		Date	E31010107V1.0
Description			

Appendix 2: Explosion drawings

KS/2 - MS Sampler (A41070019 V1.0)

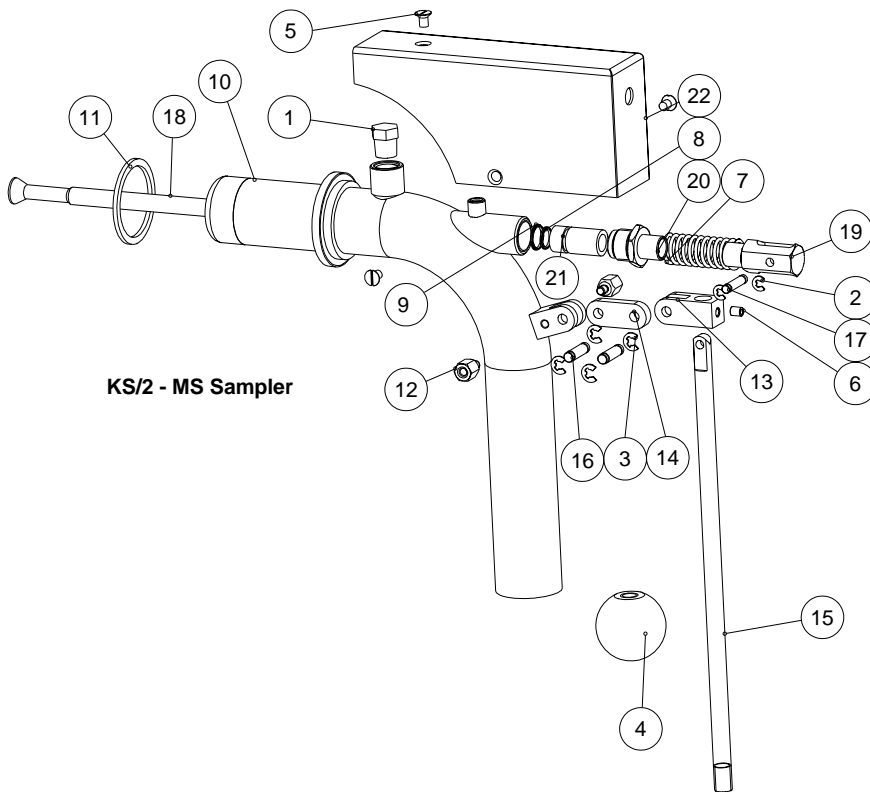

Item	Part number	Description	Value device code	Quantity
1	2000037	Plug Conical Thread	FTHPT-316-1/4	1 pcs
2	2000038	Lock Ring	4 DIN 6799 A2	2 pcs
3	2000039	Lock Ring	5 DIN 6799 A2	4 pcs
4	2000040	Ball Knob	40xM10 DIN 319	1 pcs
5	2000042	Screw	M5x8 DIN 963 A4	3 pcs
6	2000044	Screw	M5x6 DIN 916 A4	1 pcs
7	2100001	Compression Spring	SF-TFR 2x14x65	1 pcs
8	2700006	O-ring	10x1.5 FPM	1 pcs
9	2700007	O-ring	12x1.5 FPM	1 pcs
10	E31070025 V1.0	Saddle Body		1 pcs
11	H41010016 V1.0	Gasket		1 pcs
12	H41060031 V1.0	Sandoff Screw		2 pcs
13	H41070010 V1.0	Rod Clamp		1 pcs
14	H41070011 V1.0	Link		1 pcs
15	H41070012 V1.0	Rod		1 pcs
16	H41070013 V1.0	Pin 6		2 pcs
17	H41070014 V1.0	Pin 5		1 pcs
18	H41070015 V1.0	Piston for Manual Sampler		1 pcs
19	H41070016 V1.0	Spring Retainer		1 pcs
20	H41070017 V1.0	Bushing Retainer		1 pcs
21	H41070018 V1.0	Bushing		1 pcs
22	H41070030 V1.0	Cover		1 pcs

KS/2 - MT Sampler (A41070020 V1.0)

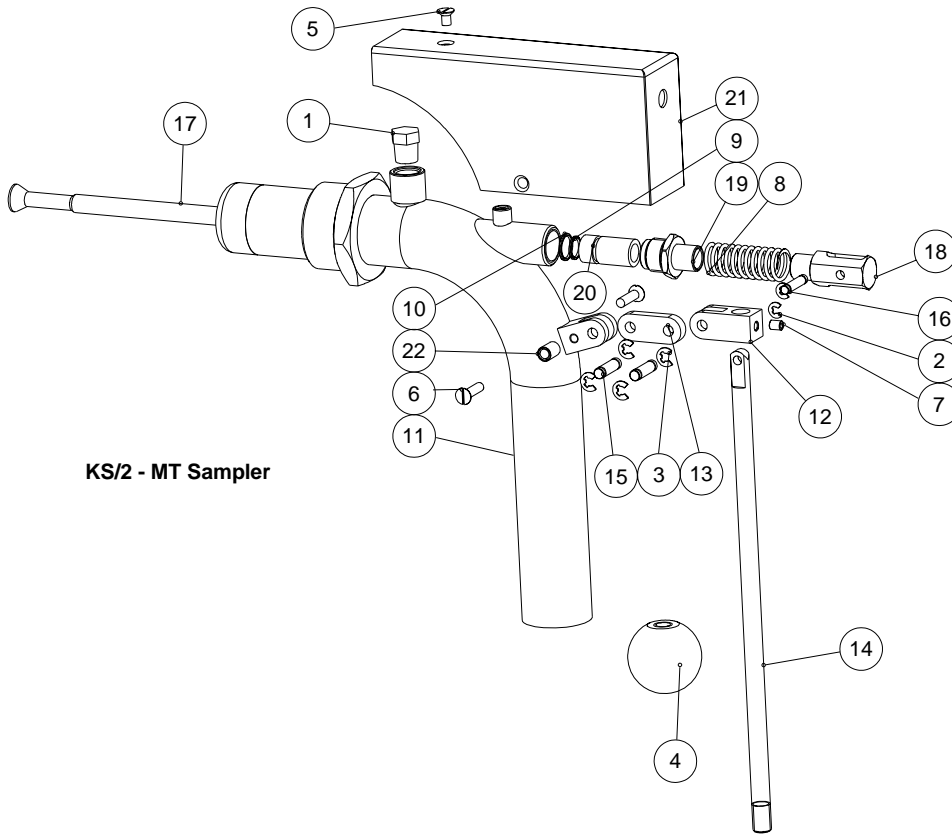

KS/2 - MT Sampler

Item	Part number	Description	Value device code	Quantity
1	2000037	Plug Conical Thread	FTHPT-316-1/4	1 pcs
2	2000038	Lock Ring	4 DIN 6799 A2	2 pcs
3	2000039	Lock Ring	5 DIN 6799 A2	4 pcs
4	2000040	Ball Knob	40xM10 DIN 319	1 pcs
5	2000042	Screw	M5x8 DIN 963 A4	1 pcs
6	2000043	Screw	M5x20 DIN 963 A4	2 pcs
7	2000044	Screw	M5x6 DIN 916 A4	1 pcs
8	2100001	Compression Spring	SF-TFR 2x14x65	1 pcs
9	2700006	O-ring	10x1.5 FPM	1 pcs
10	2700007	O-ring	12x1.5 FPM	1 pcs
11	E31070026 V1.0	Thread Body		1 pcs
12	H41070010 V1.0	Rod Clamp		1 pcs
13	H41070011 V1.0	Link		1 pcs
14	H41070012 V1.0	Rod		1 pcs
15	H41070013 V1.0	Pin 6		2 pcs
16	H41070014 V1.0	Pin 5		1 pcs
17	H41070015 V1.0	Piston for Manual Sampler		1 pcs
18	H41070016 V1.0	Spring Retainer		1 pcs
19	H41070017 V1.0	Bushing Retainer		1 pcs
20	H41070018 V1.0	Bushing		1 pcs
21	H41070030 V1.0	Cover		1 pcs
22	H41070031 V1.0	Bushing		2 pcs

KS/2 - PS Sampler (A41060001 V1.0)

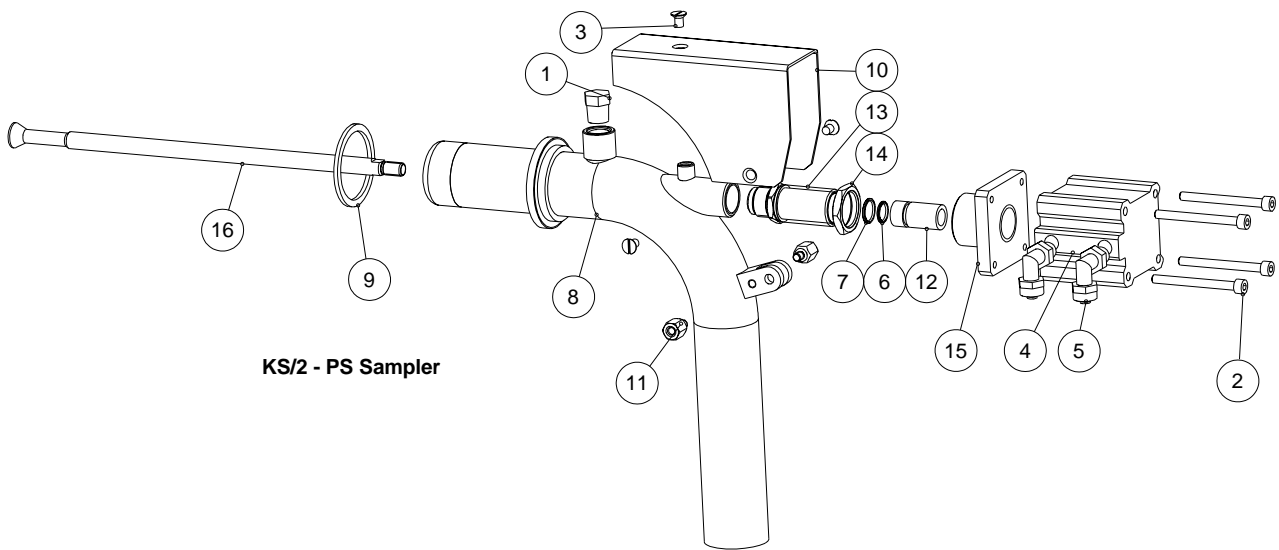

Item	Part number	Description	Value device code	Quantity
1	2000037	Plug Conical Thread	FTHPT-316-1/4	1 pcs
2	2000041	Screw	M5x55 DIN 912 A4	4 pcs
3	2000042	Screw	M5x8 DIN 963 A4	3 pcs
4	2150003	Cylinder, Short-stroke SMC	ECDQ2B 40-15D-XC6	1 pcs
5	2250001	Angle-coupling	1541-8/6-1/8 AVS	2 pcs
6	2700006	O-ring	10x1.5 FPM	1 pcs
7	2700007	O-ring	12x1.5 FPM	1 pcs
8	E31070025 V1.0	Saddle Body		1 pcs
9	H41010016 V1.0	Gasket		1 pcs
10	H41060025 V1.0	Cover		1 pcs
11	H41060031 V1.0	Sandoff Screw		2 pcs
12	H41070018 V1.0	Bushing		1 pcs
13	H41070021 V1.0	Cylinder Retainer		1 pcs
14	H41070022 V1.0	Thin Nut	M22x1.5	1 pcs
15	H41070023 V1.0	Cylinder Support		1 pcs
16	H41070029 V1.0	Piston for Pneumatic Sampler		1 pcs

KS/2 - PT Sampler (A41060002 V1.0)

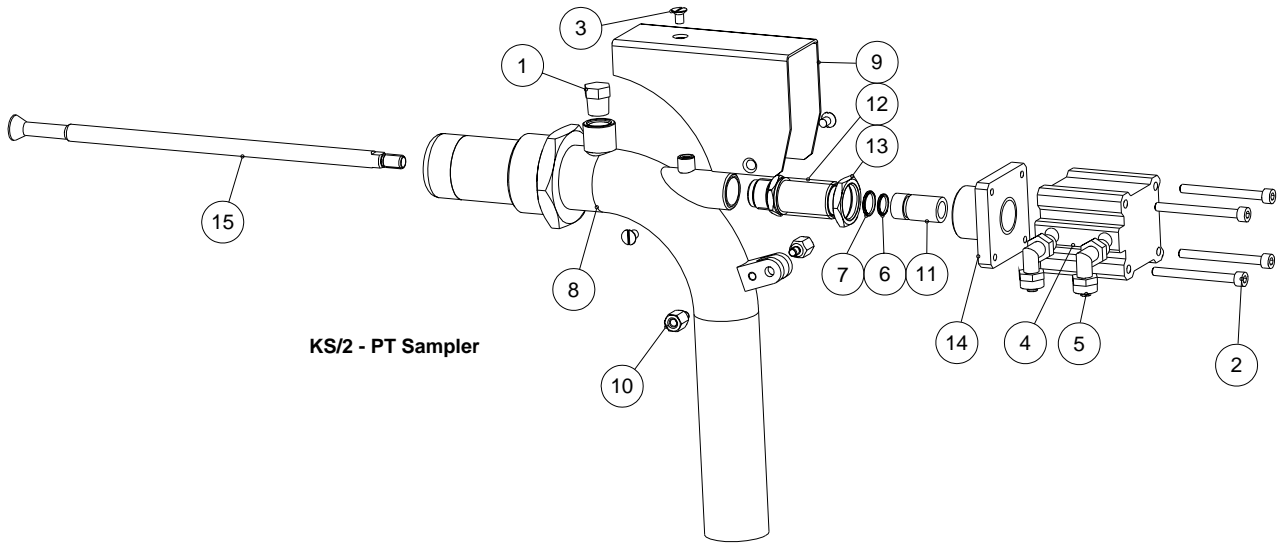

KS/2 - PT Sampler

Item	Part number	Description	Value device code	Quantity
1	2000037	Plug Conical Thread	FTHPT-316-1/4	1 pcs
2	2000041	Screw	M5x55 DIN 912 A4	4 pcs
3	2000042	Screw	M5x8 DIN 963 A4	3 pcs
4	2150003	Cylinder, Short-stroke SMC	ECDQ2B 40-15D-XC6	1 pcs
5	2250001	Angle-coupling	1541-8/6-1/8 AVS	2 pcs
6	2700006	O-ring	10x1.5 FPM	1 pcs
7	2700007	O-ring	12x1.5 FPM	1 pcs
8	E31070026 V1.0	Thread Body		1 pcs
9	H41060025 V1.0	Cover		1 pcs
10	H41060031 V1.0	Sandoff Screw		2 pcs
11	H41070018 V1.0	Bushing		1 pcs
12	H41070021 V1.0	Cylinder Retainer		1 pcs
13	H41070022 V1.0	Thin Nut	M22x1.5	1 pcs
14	H41070023 V1.0	Cylinder Support		1 pcs
15	H41070029 V1.0	Piston for Pneumatic Sampler		1 pcs

KS/4 - PS Sampler (A41010007 V1.0)

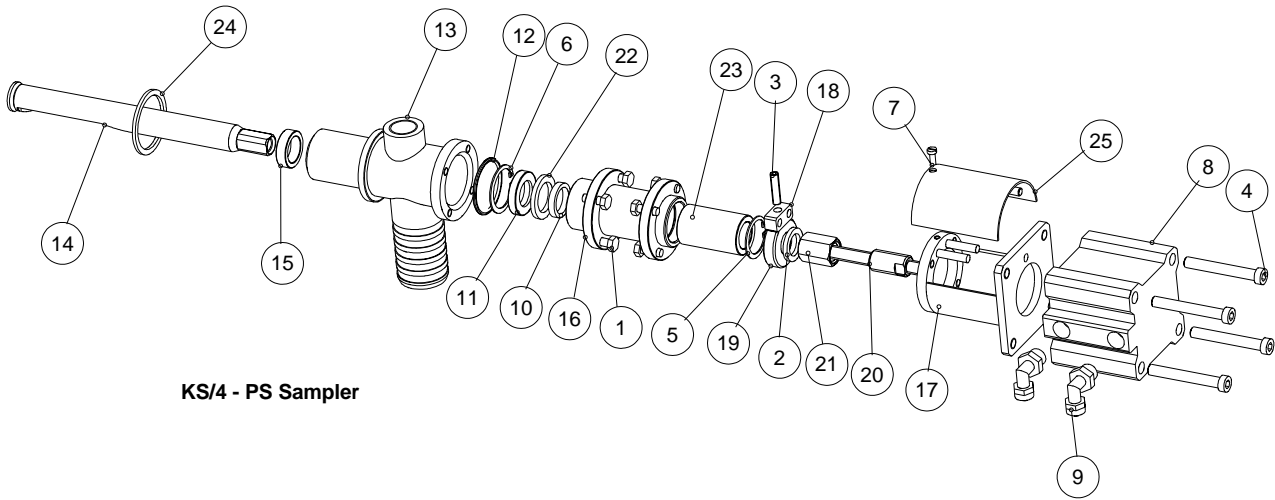

KS/4 - PS Sampler

Item	Part number	Description	Value device code	Quantity
1	2000026	Screw	M6x16 DIN 933 A4	8 pcs
2	2000029	Lock Washer	Nord-Lock M16 A4	1 pcs
3	2000030	Screw	M6x20 DIN 916 A4	1 pcs
4	2000032	Screw	M8x65 DIN 412 A4	4 pcs
5	2000033	Lock Ring	30 DIN 472 A2	1 pcs
6	2000034	Lock Ring	34 DIN 472 A2	1 pcs
7	2000036	Screw	M4*10 DIN84 A4	1 pcs
8	2150001	Cylinder, Short-stroke SMC	ECDQ2B 63-20D-XC6	1 pcs
9	2250002	Angle-coupling	1541-8/6-1/4 AVS	2 pcs
10	2650001	Rod Seal	20.0x26.2x4.8	1 pcs
11	2650002	Wiper-Scraper Seal	20x33x6.5 WM0000200-V7BBI	1 pcs
12	2700004	O-ring	38x2.5 FPM	1 pcs
13	E31010004 V1.0	Body		1 pcs
14	H41010005 V1.0	Piston		1 pcs
15	H41010006 V1.0	Cutting Ring		1 pcs
16	H41010008 V1.0	Housing		1 pcs
17	H41010009 V1.0	Cylinder Support		1 pcs
18	H41010010 V1.0	Slide		1 pcs
19	H41010011 V1.0	Setting Ring		1 pcs
20	H41010012 V1.0	Setting Bolt		1 pcs
21	H41010013 V1.0	Setting Nut		1 pcs
22	H41010014 V1.0	Seal Flange		1 pcs
23	H41010015 V1.0	Sleeve Bearing		1 pcs
24	H41010016 V1.0	Gasket		1 pcs
25	H41010050 V1.0	Cover		1 pcs

KS/4 - PT Sampler (A41010058 V1.0)

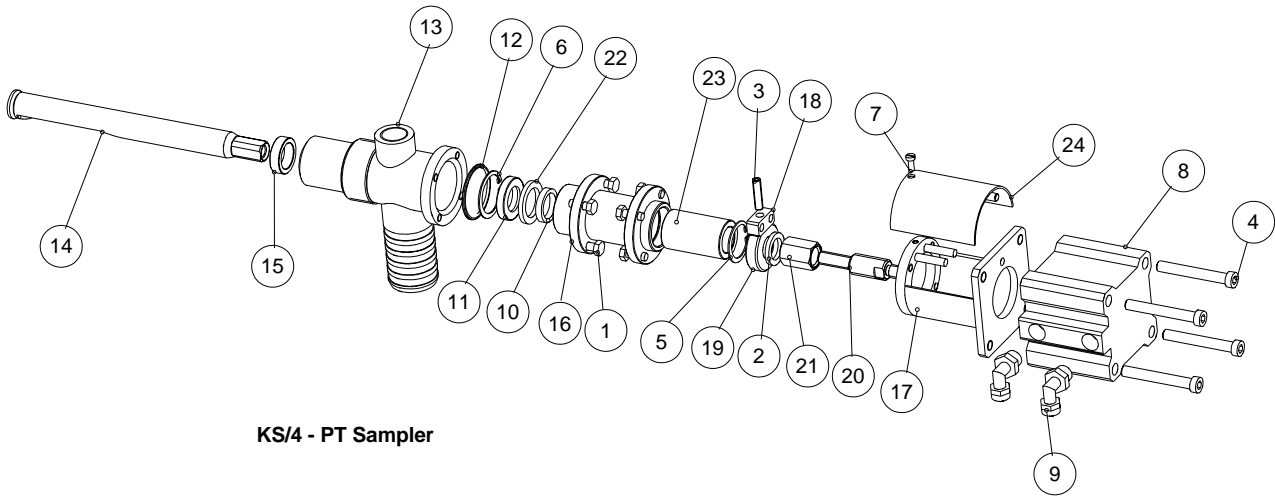

KS/4 - PT Sampler

Item	Part number	Description	Value device code	Quantity
1	2000026	Screw	M6x16 DIN 933 A4	8 pcs
2	2000029	Lock Washer	Nord-Lock M16 A4	1 pcs
3	2000030	Screw	M6x20 DIN 916 A4	1 pcs
4	2000032	Screw	M8x65 DIN 412 A4	4 pcs
5	2000033	Lock Ring	30 DIN 472 A2	1 pcs
6	2000034	Lock Ring	34 DIN 472 A2	1 pcs
7	2000036	Screw	M4*10 DIN84 A4	1 pcs
8	2150001	Cylinder, Short-stroke SMC	ECDQ2B 63-20D-XC6	1 pcs
9	2250002	Angle-coupling	1541-8/6-1/4 AVS	2 pcs
10	2650001	Rod Seal	20.0x26.2x4.8	1 pcs
11	2650002	Wiper-Scraper Seal	20x33x6.5 WM0000200-V7BBI	1 pcs
12	2700004	O-ring	38x2.5 FPM	1 pcs
13	E31010059 V1.0	Body		1 pcs
14	H41010005 V1.0	Piston		1 pcs
15	H41010006 V1.0	Cutting Ring		1 pcs
16	H41010008 V1.0	Housing		1 pcs
17	H41010009 V1.0	Cylinder Support		1 pcs
18	H41010010 V1.0	Slide		1 pcs
19	H41010011 V1.0	Setting Ring		1 pcs
20	H41010012 V1.0	Setting Bolt		1 pcs
21	H41010013 V1.0	Setting Nut		1 pcs
22	H41010014 V1.0	Seal Flange		1 pcs
23	H41010015 V1.0	Sleeve Bearing		1 pcs
24	H41010050 V1.0	Cover		1 pcs

KS/6 - PS Sampler (A41010037 V1.0)

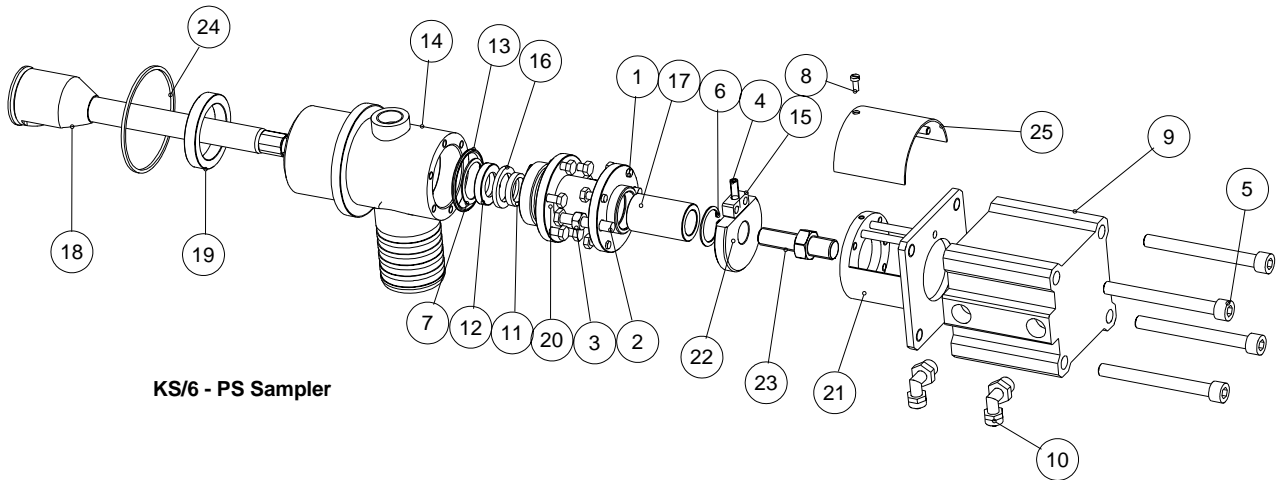

KS/6 - PS Sampler

Item	Part number	Description	Value device code	Quantity
1	2000026	Screw	M6x16 DIN 933 A4	10 pcs
2	2000027	Screw	M8x45 DIN 933 A4	2 pcs
3	2000028	Hex nut	M8 DIN 934 A4	2 pcs
4	2000030	Screw	M6x20 DIN 916 A4	1 pcs
5	2000031	Screw	M10x100 DIN 912 A4	4 pcs
6	2000033	Lock Ring	30 DIN 472 A2	1 pcs
7	2000034	Lock Ring	34 DIN 472 A2	1 pcs
8	2000036	Screw	M4*10 DIN84 A4	1 pcs
9	2150002	Cylinder, Short-stroke SMC	ECDQ2B 80-40D-XC6	1 pcs
10	2250002	Angle-coupling	1541-8/6-1/4 AVS	2 pcs
11	2650001	Rod Seal	20.0x26.2x9.8	1 pcs
12	2650002	Wiper-Scraper Seal	20x33x6.5 WM0000200-V7BBI	1 pcs
13	2700005	O-ring	44.2x3 FPM	1 pcs
14	E31010034 V1.0	Body		1 pcs
15	H41010010 V1.0	Slide		1 pcs
16	H41010014 V1.0	Seal Flange		1 pcs
17	H41010015 V1.0	Sleeve Bearing		1 pcs
18	H41010035 V1.0	Piston		1 pcs
19	H41010036 V1.0	Cutting Ring		1 pcs
20	H41010038 V1.0	Housing		1 pcs
21	H41010039 V1.0	Cylinder Support		1 pcs
22	H41010041 V1.0	Setting Ring		1 pcs
23	H41010042 V1.0	Setting Bolt		1 pcs
24	H41010046 V1.0	Gasket		1 pcs
25	H41010051 V1.0	Cover		1 pcs

Appendix 3: Recommended spare parts

KS/2-MS Recommended Spare Part Kit A41070046V1.0

Order code:	Description:
2100001	Compression Spring
2700006	O-ring 10*1,5 FPM
2700007	O-ring 12*1,5 FPM
H41010016 V1.0	Gasket
H41070015 V1.0	Piston for Manual Sampler

KS/2-MT Recommended Spare Part Kit A41070047V1.0

Order code:	Description:
2100001	Compression Spring
2700006	O-ring 10*1,5 FPM
2700007	O-ring 12*1,5 FPM
H41070015 V1.0	Piston for Manual Sampler

KS/2-PS Recommended Spare Part Kit A41070048V1.0

Order code:	Description:
2150003	Cylinder, Short-stroke SMC
2700006	O-ring 10*1,5FPM
2700007	O-ring 12*1,5 FPM
H41010016 V1.0	Gasket
H41070029 V1.0	Piston for Pneumatic Sampler

KS/2-PT Recommended Spare Part Kit A41070049V1.0

Order code:	Description:
2150003	Cylinder, Short-stroke SMC
2700006	O-ring 10*1,5 FPM
2700007	O-ring 12*1,5 FPM
H41070029 V1.0	Piston for Pneumatic Sampler

KS/4-PS Recommended Spare Part Kit A41070087V1.0

Order code:	Description:
2150001	Cylinder, Short-stroke SMC
2650001	Rod Seal 20x26,2x9,8
2650002	Wiper-Scraper Seal 20x33x6,5
2700004	O-ring 38*2,5 FPM
H41010005 V1.0	Piston
H41010006 V1.0	Cutting Ring
H41010010 V1.0	Slide
H41010011 V1.0	Setting Ring
H41010016 V1.0	Gasket

KS/4-PT Recommended Spare Part Kit A41070088V1.0

Order code:	Description:
2150001	Cylinder, Short-stroke SMC
2650001	Rod Seal 20x26,2x9,8
2650002	Wiper-Scraper Seal 20x33x6,5
2700004	O-ring 38*2,5 FPM
H41010005 V1.0	Piston
H41010006 V1.0	Cutting Ring
H41010010 V1.0	Slide
H41010011 V1.0	Setting Ring

KS/6-PS Recommended Spare Part Kit A41070089V1.0

Order code:	Description:
2650001	Rod Seal 20x26,2x9,8
2650002	Wiper-Scraper Seal 20x33x6,5
2700005	O-ring 44,2*3 FPM
H41010010 V1.0	Slide
H41010035 V1.0	Piston
H41010036 V1.0	Cutting Ring
H41010041 V1.0	Setting Ring
H41010046 V1.0	Gasket

Appendix 4: Specifications

CONSISTENCY RANGE	KS/2: Low consistency 0 - 8%Cs screened pulp KS/4: Low consistency 0 - 8%Cs screened and unscreened pulps, no knots. KS/6: Medium consistency 0 - 18%Cs screened and unscreened pulps.
PROCESS CONNECTION	KS/2: NS40 Sandvik Saddle or threaded NPT1½" KS/4: NS40 Sandvik Saddle or threaded NPT1½" KS/6: NS70 Sandvik Saddle
FLUSH WATER CONNECTION	KS/2: R¼" internal thread, compatible with NPT¼" KS/4: R½" external thread, compatible with NPT½" KS/6: R½" external thread, compatible with NPT½"
FLUSH WATER PRESSURE	2 - 10 bar (30 - 150 psi)
AIR PRESSURE (P-models)	KS/2: 2 – 10 bar (30 – 150 psi), KS/4: 2 – 10 bar (30 – 150 psi), recommendation min 4 bar (60 psi) KS/6: 5 – 10 bar (30 – 150 psi), recommendation min 5 bar (75 psi)
SAMPLE OUTLET CONNECTION	KS/2: 38mm, (1 ½") hose connection KS/4: 38mm (1 ½") hose connection or 38mm (1 ½") flanged outlet KS/6: 50mm (2") hose connection or 50mm (2") flanged outlet
PROCESS PRESSURE	Maximum pressure: 25 bar (370 psi) The minimum operating pressure required is a function of the sample consistency. KS/2 and KS/4 min. process pressure: KS/6 min. process pressure: 0 - 3 % 0.5 bar (7 psi) below 8% 1.0 bar (15 psi) 3 - 5 % 1.0 bar (15 psi) over 8% 2.0 bar (30 psi) 5 - 8 % 2.0 bar (30 psi)
SAMPLE FLOW	The sample flow is a function of process pressure, fiber type and consistency. The flow diminishes at higher consistencies. KS/2 pneumatic, KS/4 and KS/6 piston stroke opening and piston orientation are adjustable.
MATERIALS	Standard wetted parts AISI 316L. Titanium available for KS/2 & KS/6
WEIGHT	KS/2-M: 1.8 kg KS/2-P: 2.0 kg KS/4: 2.3 kg KS/6: 3.7 kg
OPTIONS	Electric position switch of sampling piston for stamping the time in the DCS.